

LINEAR ENAMEL HYPOPLASIA AT SANTA RITA COROZAL, BELIZE

by

ANDREW PETER TETLOW  
B.A. University of Central Florida, 2003

A thesis submitted in partial fulfillment of the requirements  
for the degree of Master of Arts  
in the Department of Anthropology  
in the College of Sciences  
at the University of Central Florida  
Orlando, Florida

Fall Term 2010

© 2010 Andrew Peter Tetlow

## **ABSTRACT**

The focus of this thesis is an analysis of a sample of dentition collected from the Postclassic Maya site of Santa Rita Corozal in Northern Belize. The goal of this study is to determine what the presence (or absence) of Linear Enamel Hypoplasia (LEH) can demonstrate about the general health (i.e. stress, disease, nutrition, and weaning age) and social status of a single subset of the Late Postclassic (900-1500 CE) Maya living at Santa Rita Corozal. Specifically, this thesis focuses on dentition of thirteen individuals from a large Postclassic platform group. The sample consists of sub-adult and adult female dentition from individuals that are associated with the same relative time period (Late Postclassic).

The question being addressed in this thesis is: why has LEH presented in these individuals? These samples will also be compared to other studies involving LEH throughout the Maya area, in both similar and dissimilar environments. The preponderance of female and sub-adult remains also makes this platform group a very interesting topic of study for LEH in the Maya area, as it is unusual to find a concentrated area of individuals such as these.

Importantly, the results of this study show that there is no significant relationship between general levels of stress and the overall status of an individual. Measurements collected from the LEH affected teeth demonstrate that all of the LEH episodes occurred before the age of 6. The mean age for the teeth sampled that show signs of LEH is 3.5 years, which is consistent with theories pertaining to the weaning age of the Maya during concomitant time periods. However, the size of this sample precludes any concrete conclusions about weaning ages and stress in general among the Maya at Santa Rita Corozal. It is also possible that these events are related to larger issues such as regional droughts or water-borne disease.

## **ACKNOWLEDGMENTS**

This thesis was made possible by the tireless efforts of my friends and family, whose support and unwavering dedication are among the only reasons this project has come to fruition.

Thanks must go to Drs. Arlen and Diane Chase, whose continuing patience and insistence that I should not surrender have helped keep me on track, even though the track may have been longer than all would have expected. Their constant assistance, particularly with allowing me to use their excellent collection and notes from Santa Rita Corozal made this research possible as well, who knows where it may have ended up without such ready sources of reliable data. The funding provided through the UCF Federal Work Study program by the Drs. Chase and the opportunity to work in the Archaeology Laboratory for many years under the Chases was also invaluable for the completion of this thesis. The opportunities presented by the Chases' and others at UCF and UC Boulder to work in the field have also changed my life for the better in more ways than I can count and it is deeply, deeply appreciated.

Thanks also to Dr. Tosha Dupras, whose expertise in the analysis of osteological material and specifically dentition was invaluable. This project could not have succeeded without her guidance and tireless efforts to edit this work and help me

along this path. She is quite simply one of the best people I have ever met in academia.

Credit must also go to my fellow graduate students at UCF for their ideas and articulate critiques, which are invaluable and highly necessary during any serious writing process. Thanks to Lucas Johnson, James Crandall, Amanda Groff and Jorge Garcia, the best sounding board anyone could ask for.

Of course a great deal of the credit for this project must go to my family, Martha and Philip Tetlow, who constantly helped keep their son on the proper path with gentle prodding, not only during the writing of this thesis, but also throughout the rest of life as well.

The State of Florida and the Florida Park Service must also be acknowledged for their contribution to the writing of this work. Dr. Robert Charles Brooks, Park Manager, has been unwavering in his support of this pursuit, along with Environmental Specialist Jon Meyer and Environmental Specialist II Steven Giguere. The opportunity to work with these fine individuals and the professional organization that is the Florida Park Service is my distinct privilege and honor. It is rare to find an organization that you would be honored to work with for your entire life, and I have found such a place.

However, the person most responsible for encouraging me to produce the finished product of this thesis is my wife, Megan Paduchowski. She has listened to me talking about teeth and LEH for years and for that she is truly a strong and patient woman. Without her constant support and faith in me I am unsure if this work would have ever been completed.

For Megan



## TABLE OF CONTENTS

LIST OF TABLES .....	x
LIST OF FIGURES .....	xi
CHAPTER ONE: INTRODUCTION.....	1
Santa Rita Corozal: A Brief History .....	6
Platform Two: Where it all began.....	9
The Human Remains.....	10
Ritual and Status at Platform 2 .....	12
CHAPTER TWO: CURRENT LITERATURE RELATED TO LINEAR ENAMEL	
HYPOPLASIA AND ITS RELATIONSHIP TO MAYA ARCHAEOLOGY .....	18
Enamel Formation.....	24
Linear Enamel Hypoplasia in the Maya Area.....	35
CHAPTER THREE: METHODOLOGY .....	62
CHAPTER FOUR: RESULTS .....	66
CHAPTER FIVE: DISCUSSION AND CONCLUSION .....	71
APPENDIX A: TABLES.....	77
APPENDIX B: FIGURES .....	81
REFERENCES CITED.....	102

**LIST OF TABLES**

Table 1 ..... 78  
Table 2 ..... 79  
Table 3 ..... 80

## LIST OF FIGURES

Figure 1: Overview of Belize with Santa Rita Corozal indicated.....	82
Figure 2: Map of Santa Rita Corozal.. .....	83
Figure 3: Modern satellite view of Corozal town.. .....	84
Figure 4: Enlarged view of Platform 2 and Structure 81.....	85
Figure 5: Plan view of Late Postclassic burials located directly south of Platform 2.. .....	86
Figure 6: Case Example of LEH present on the dentition of a 12-year-old child. ....	87
Figure 7: Case Example of Linear Enamel Hypoplasia present on two incisors.....	88
Figure 8: Extreme LEH banding apparent on dentition from P6E36 SDP6E-1. ....	89
Figure 9: LEH Dentition from P6E36 SDP6E-1.....	90
Figure 10: LEH Dentition from P6E36 SDP6E-1.....	91
Figure 11: LEH Dentition from P6E36 SDP6E-1.....	92
Figure 12: LEH Dentition from P6E82 SDP6E-7.....	93
Figure 13: LEH Dentition from P6E83 SDP6E-8.....	94
Figure 14: LEH Dentition from P6E83 SDP6E-8.....	95
Figure 15: LEH Dentition from P6E83 SDP6E-8.....	96
Figure 16: LEH Dentition from P6E83 SDP6E-8.....	97
Figure 17: LEH Dentition from P6E87 SDP6E-11.....	98
Figure 18: LEH Dentition from P6E87 SDP6E-11.....	99
Figure 19: LEH Dentition from P6E87 SDP6E-11.....	100
Figure 20: LEH Dentition from P6E88 SDP6E-12.....	101

## **CHAPTER ONE: INTRODUCTION**

This thesis is focused on the link between episodic health issues and how these relatively short periods of stress can impact the larger and more ephemeral topics of general social and economic well-being within Maya society. These episodic health issues can be identified in the archaeological record through the study of Linear Enamel Hypoplasia. Examinations of dentition and more specifically determining the presence or absence of Linear Enamel Hypoplasia (LEH) can serve as an excellent indicator of the general level of stress for a group of individuals.

The teeth examined in this thesis come from sub-adults and adult females all recovered from the same general locus within the site of Santa Rita Corozal, Belize. The presence of LEH suggests that these individuals suffered from some form of stress (malnutrition, disease, improper weaning, serious injury, etc) during the early development of their dentition. The primary research question of this thesis is: why do we see these examples of LEH occurring in this specific group of individuals, and what does it mean?

If several examples of LEH can be identified among a group, then a general trend can be inferred and may serve to identify a

common event or overall level of stress within the sample group. However, inferences about the larger population would likely be inaccurate as a larger sample spanning a wider area of the site and from broader contexts would be needed for any such site-wide conclusions. This may also add to the store of knowledge concerning the social and/or ritual organization of Maya society, as the sample group is in some instances associated with ritual activity, as will be discussed later. The larger contribution will likely be more geared towards future work in the study of stress within Maya populations and how these stressful events trigger the formation of such signs as LEH. This has implications not only for the specific health of an individual or small group, but may also be indicative of economic and social stability as well (in a more limited sense).

This relationship between health and social conditions is most aptly described by Goodman and Armelagos (1988:942):

....may result from differential lifelong patterns of behaviorally and culturally based exposure to stressors. An increased lifelong potential for exposure to stressors may cause both an increased frequency of childhood stress and earlier ages at death....this relationship is mainly due to social conditions present at childhood, which are likely to persist into adult life.

This stress to social conditions relationship can be associated with the elite of Maya society (as well as to lower

tiers of the social ladder). While smaller in number, the elite members of Maya civilization (and the children that were born into this social system) were at the same time serving an important regulatory function within Maya society. Managing ritual and economic networks with other centers across the Maya area was an important part of day-to-day administration. This was an important activity, not only for the elite individuals and for the maintenance of their status, but also for the more prevalent commoners, which are the foundation of all great civilizations.

Cucina and Tiesler (2003:1) argue that there is a clear division between different classes based upon differential access to resources (and the resulting stress) and that this difference results in a clear pattern of "nutritional and pathological conditions" among the Maya elites. The author's state that one of the major problems with studying this relationship is that there is a great deal of contradictory evidence from the Maya area. In this case, this evidence (which is detailed in Chapter two) demonstrates that Maya elites do not necessarily always have a smaller percentage of caries than their commoner counterparts (Cucina and Tiesler 2003:6), which one might expect due to their status.

Also of note, there is a clear division between the frequency of caries among elite males and females with females having a higher frequency of caries than males of the same social status (Cucina and Tiesler 2003:6). The authors suggest that this may be indicative of differential access to cariogenic foods not only between the elite and commoners but among the sexes of the elite as well (Cucina and Tiesler 2003:6). An intriguing comparison is also described, in which there is little to no difference between the frequency of caries among the sexes in the commoner segment of society (Cucina and Tiesler 2003:7). However, it should be noted that elite individuals also demonstrated a relatively high rate of calculus, indicating that oral hygiene was not necessarily an important concern for the elite Maya (Cucina and Tiesler 2003:8).

The samples examined for this study are from a high status platform group (Platform 2 at Santa Rita Corozal) and show very little calculus despite the fact that both adults and sub-adults were examined. The significance of this remains rather inconclusive due to the fact that many of the interments are associated within a distinctive burial context. These individuals were also possibly related, as this platform group was the likely residence of a single extended family at Santa Rita. This suggests that the distinctive nature of the burials

may have been a standard practice for this specific group or family.

The study of episodic health issues can be telling of the overall stability of a specific population. If there are a large number of cases of LEH within a population, representing multiple episodes of stress per individual, then this indicates that there are periodic episodes of physiological stress occurring within this small sample of the Maya population at Santa Rita Corozal. This may hint that there are broader issues of stress occurring at SRC and that an episodic health condition such as LEH is not an isolated event, but is part of a settlement wide concern (such as a drought) that may be affecting many more individuals. Further study would be required to determine that with certainty.

The Postclassic represents a fascinating period of time for Maya society in general. It was often (incorrectly) thought to be associated with an overall decline in the quality of artistic works and architectural achievement. However, at sites such as Santa Rita there were relatively large populations living in a very complex society that existed right up until contact with the Spanish occurred (Chase and Chase 1988:2). This period at Santa Rita, leading up to European contact, offers a fascinating glimpse of a society that was in its prime and very active not



only within its own sphere of influence but also within the broader network of Maya centers and satellite sites. It is the last glimpse that we have of an unadulterated view of the Maya civilization before its diffusion at the hands of European intruders.

The question posed by this thesis is whether or not the Maya individuals living at Santa Rita Corozal were undergoing periods of physiological stress, despite living in an area of relative abundance on the northern coastline of Belize. Is it possible that indications of stress in these individuals are indicative of a population wide stress? Although it is possible, it is more likely that the each example of linear enamel hypoplasia is the result of a single stress episode (e.g., injury, malady, or nutritional deficiency) isolated to a single individual or small group, such as the one examined on the following pages.

#### Santa Rita Corozal: A Brief History

The site of Santa Rita Corozal was selected for this study because it possessed a readily available osteological collection that could be analyzed to assess the overall stress levels of a small group of likely elite individuals. Santa Rita occupied from the Early-Middle Preclassic, but was primarily a

Postclassic (900- 1500 CE) Maya site. It is situated on the coast of north-eastern Belize (Figure 1) and is, for the most part, buried directly beneath the modern Belizean city of Corozal Town (Figures 2, 3; Chase and Chase 1986:3). This intrusion by modern occupation has resulted in relatively poor preservation, which is not aided by the high atmospheric salinity caused by close proximity to the ocean.

During the site's most populous period Santa Rita boasted a population of approximately seven-thousand individuals, which was immediately prior (~ 200 years) to the initial contact between the Maya and Spanish in 1517 (Chase 1997:16; Sharer and Traxler 2006:615). This important site possesses a great deal of information on an extremely wide variety of topics, the importance of ritual behavior being one of the most fascinating (Chase 1991:89). This ritual behavior and the associated activities are important to the study of the Postclassic period, as well as previous time periods (Chase and Chase 1981:1-2; Chase 1985:104). The unique nature of Santa Rita is concisely summarized by Sharer and Traxler (2006:610-611):

The archaeological site of Santa Rita Corozal was a major center within the Chetumal polity. Heavily disturbed by present-day occupation, most of the archaeological remains are poorly preserved. But archaeological research has revealed a long span of occupation prior to the Spanish Conquest. The presence of murals at Postclassic sites along the east coast attests to the economic prosperity of these

commercial cities at the end of the pre-Columbian era. Most appear to be the work of skilled foreign artists commissioned by wealthy local elite. Close economic ties with Yucatan are indicated by effigy incensarios and pottery related to that of Mayapan found in these east-coast sites.

Santa Rita's origins lay during the early Preclassic period with what was at that time likely a small and rather modest coastal settlement that supported perhaps two to three hundred people. While Santa Rita may not have had many of the impressive monumental constructions that can be found throughout much of the Maya area, there was nevertheless a thriving community that subsisted primarily upon the bounty of the sea and wide trade networks that worked their way up and down the coast of the Yucatan.

The first excavations conducted at Santa Rita were undertaken by Thomas Gann during the early 1900s (Chase and Chase 1980:1). Gann made a number of fascinating discoveries, including the large mural discussed in the quote above (Chase 1981:25; Sharer and Traxler 2006:615). However, the most intensive excavations conducted at Santa Rita were organized by Drs. Diane and Arlen Chase during the late 1970s through the early 1980s. During these field seasons the site was mapped and a wide variety of information was collected from numerous

excavations, including those that produced the sample that this thesis is based upon.

#### Platform Two: Where it all began

Platform 2 is located in the northeast sector of Santa Rita. This location is where the sample of dental material used in this thesis originates. The platform supported six separate residential buildings as well as an area that may have been used for ritualized ceremonies (Fig. 4). Platform 2 is also associated with several interments consisting of 6 adult females and 7 sub-adult remains (Chase and Chase 1988:26). With the exception of SDP6E-1 (Lot P6E/36) and SDP6F-1 (Lot P6F/53) the sub-adults and adult remains are buried in separate locations within the area of Platform 2 (see Table 1). In SDP6E-1 there are a total of four sub-adults buried with one possible adult female. In SDP6F-1 there is one sub-adult interred with a single adult female. This platform was selected because it contains the largest number of Postclassic interments of any structure at Santa Rita Corozal, and as such made for a manageable sample that could be used to discern evidence of LEH within a small group. Chase (1988:25; Chase 1982:337-340,349-350) describes Platform two as being:

....the most massive Postclassic construction excavated during Corozal Postclassic Project investigations at Santa Rita Corozal. It measured approximately 44.0 m by 36.5 m and was 2.0 m in height. It was surmounted by Structures 73, 76, 77, 78, 79 and 80. Investigations were undertaken in this locus during both 1979 and 1980 and consisted of trenching and wider aerial clearing....Excavation of Platform 2 revealed that the earliest occupation of this locus was during the Late Preclassic era....The major period of occupation for this locus appears to have been during the Late Postclassic Period, when there is evidence for several stages of construction activity and extensive re-building.

It is also important to note that Structure 81 (which is located immediately to the northeast of Platform 2) was most likely the dwelling of a high ranking leader "of a ward or town" (Figure 4; Roys 1957:170). The methods of construction used in this structure also support the idea that a "principal" lived here as well, as it is much more lavishly built than the home of an ordinary Maya individual would be (Chase 1982:574-575). However, the story of the numerous interments within Platform Two is where the nexus of this thesis lies.

#### The Human Remains

The purpose of this section is to place the dental samples used in this thesis into a more specific context. Thus, a straightforward and concise overview of the various burials recovered from Platform 2 will be described below. Since this

thesis deals with interments that contain both evidence of the presence and absence of LEH, all the burials related to Platform 2 will be briefly discussed. A plan view of the majority of these interments can be seen in Figure 5, which will assist in adding spatial context to the description of these burials.

Within the space between Structures 73 and 80 (Figure 4) there was one set of incomplete remains recovered (due to poor preservation, which is an issue for much of the skeletal material from SRC), found in an extended position (Chase and Chase 1988:26). Within the platform itself there was "a multiple sub-adult interment" (SDP6E-1 containing four sub-adults and one adult female) that was located when an axial trench was excavated through the platform structure (Chase and Chase 1988:26). These remains were also directly associated with a possible altar (Figure 4), suggesting that these burials were directly associated with some form of ritualized activity, the exact nature of which is unknown (Chase and Chase 1988:26).

The densest concentration of remains within the area of Platform 2 is situated in a location that is directly south of the construction. In this locus there were six separate burials contained within a number of depressions that contained both adult females and sub-adults, which forms a rather compelling concentration of remains (Chase and Chase 1988:26). The absence

of adult males from these burials suggests a number of possibilities, which will be examined in more detail in the following sections.

Within Structure 73 several individuals were recovered during the excavation of an axial trench through the structure (Figure 5; Chase and Chase 1988:26). The last set of remains examined was recovered from Structure 77 and was associated with two destroyed censers (Chase and Chase 1988:27), which may have been ritually smashed to commemorate the interment of these individuals or in recognition of an important ritualized activity.

#### Ritual and Status at Platform 2

The importance of ritual activity not only for the maintenance of the image of the Maya elite, but also for the perceived safety and security of the site itself cannot be understated. The association of individuals within this sample group with such ritual activity may also shed light on the specific types of people that were participating in such activity and whether they were in fact members of the elite or perhaps belonged to another sub-set of Maya society. In any case, the failing of the health (as the result of any number of stressors) of elite individuals would have resulted in a

disruption in this highly organized activity and as a result the site as a whole would have suffered, not just a single aspect of Maya society.

Ritual activities at Santa Rita Corozal can be broadly defined as organized activity with a special spiritual or religious connection that follows many patterns that can be observed in the archaeological record across the Maya area. These activities are typically associated with certain types of artifacts, although that is a general statement and not always necessarily true (directionality and body placement can also have special significance). These artifacts can include a wide variety of specialized ceramics, such as censerware, which are ceramic vessels modeled on the theme of a ceiba tree, which has special significance in Maya mythology.

While this ritual aspect of the interments is fascinating in its own right it also presents somewhat of a problem. The presence of ritual activity means that this platform group may not necessarily be indicative of groups of this type across Santa Rita as a whole. The types of individuals present at Platform Two may also be different from the typical occupants of such a structure at other locations within Santa Rita. While these are admittedly limitations, there is also a great deal that the study of this isolated population can tell us.



Particularly when added to later studies that include examinations of a larger sample from across the site as a whole.

The interments containing dentition from Platform Two totaled thirteen individuals, consisting of six adult females and seven sub-adults. The artifacts associated with these remains, as well as their association with ritual constructions, suggests that these individuals may in fact have served a ritualized role in the social order of Santa Rita Corozal or in the extended family group of Platform 2. These individuals certainly were associated with some measure of importance, either through their ritual contribution or through their hierarchal status. It is also certainly apparent that this platform as a whole and specifically Structure 77, was associated with some sort of ritualized or religious activity (Chase 1982:577-578).

While these individuals are all associated with a relatively high status platform group, this does not necessarily suggest that they were all of equal social status. The nature of some of these interments suggests that there was some social status variation between these individuals as well. This is based upon the artifacts associated with each interment, which range from relatively simple grave goods of a few beads, to more elaborate ritual ceramic vessels and obsidian. Such as SDP6E-1,

which was associated with a possible rectangular altar (Chase 1982:323). These individuals were also found interred with a number of ritual ceramic vessels, as well as other artifacts such as a small amount of obsidian, a spondylus shell bead, chert, and several beads of varying composition (Chase 1982:325). All of these artifacts are likely burial offerings that were included by the families of the interred individuals.

One individual (SDP6E-7) was found buried with a copper ring on each hand, along with a pair of spondylus shell beads (Chase 1982:326). The presence of these rings suggests that while this individual may not have been a member of the most elite level of society at Santa Rita, she was most likely not a commoner. It is possible that she may have been a foreigner traveling through this area, as Santa Rita's position on the coast of Belize made it a nearly ideal trading location. There is also no clear ritual association with this burial, but the fact that this is the westernmost interment does make that determination less certain.

SDP6E-4, although not present in this sample, was the easternmost burial. While this easternmost association does suggest some possible ritual significance, the nature of the interment does not. This sub-adult was buried facedown in a tightly flexed position with only a single bead present in

association with the interment (Chase 1982:329). This interment is included as an example that an individual does not necessarily need to be of elite origin to have been interred in this platform group and that this burial may have had a strict ritual significance. However, the lack of any ceramic or other artifactual evidence of a ritual nature makes this possible association problematic. The lack of any recovered dental material also eliminated this individual from the LEH sample.

The burial with the individual from SDP6E-6 contained a number of ritualized artifacts. There was a variety of smashed ceramic vessels present above the remains, which does suggest that there was some sort of ritual activity associated with this individual. The presence of smashed vessels may have indicated the conclusion of a ceremony of some sort. However the specific status of this individual remains questionable. SDP6E-12 was also an adult female and was associated with a pair of smashed ceramic vessels. This interment also shows possible signs that some sort of similar ritualized activity was taking place at this burial as well as at SDP6E-6.

SDP6E-8 was a young sub-adult that may have been interred along with a variety of refuse (that does not appear to have any apparent ritual significance) and as such does not appear to have either been related to a ritual ceremony or to a high

status group at Santa Rita. SDP6E-11 also contained a sub-adult with no visible signs of either status (only 2 beads; ceramic and spondylus, were recovered) or of ritual activity.

The variation within this sample group in regards to relationships between status, LEH, and ritualized activity certainly does not serve to paint a clear picture of what was occurring at this platform group. However, it can be said that in general the majority of these individuals were associated with some form of ritual activity, but what this association says about the individuals' specific status (in the majority of cases) is unclear. The question then becomes: Why do we see examples of linear enamel hypoplasia within this sample group? To understand this it is necessary to examine some of the more current literature and background material on LEH itself and the various processes that result in the formation of this unique and very telling feature on the dentition of these long deceased individuals.

## **CHAPTER TWO: CURRENT LITERATURE RELATED TO LINEAR ENAMEL HYPOPLASIA AND ITS RELATIONSHIP TO MAYA ARCHAEOLOGY**

LEH is most commonly described as a cessation in the growth of dental enamel (McHenry and Schulz 1976:1). One of the possible causes for this could be nutritional deficiencies; however there are also a wide range of other possible stressors, such as illness, the weaning process (which will be examined in later chapters), or some manner of traumatic injury that has weakened the body as a whole and thus interrupting the formation of enamel. This condition commonly occurs during the initial growth of enamel during childhood (Goodman et al. 1991:773). The presence of LEH in this particular sample shows continued growth and survivorship after the stressor occurred (Suckling 1989:90; Wood et al. 1992:355).

Linear enamel hypoplasias commonly manifest as horizontal striations across the labial surface of the incisors and canines, but can also occur on any individual tooth in the dentition. The analysis of linear enamel hypoplasia within the archaeological and osteological record has been shown to provide interesting information regarding stressors such as early childhood levels of nutrition (Mendez Colli et al. 2009), weaning age of infants (Wright and Schwarcz 1998), and traumas or illnesses (Wright 1990:26).

The analysis of LEH can also be particularly useful when dealing with osteological remains in an area where preservation is exceedingly poor. This is particularly true in the dense humid jungles of the Maya area, or in the higher salinity environment that Santa Rita Corozal is situated in due to its location on the eastern coast of the Yucatan. The use of LEH analysis is made all the more important in an environment with poor preservation because without intact and high quality skeletal material the use of dental analysis becomes one of the best methods that can be used to deduce (to some extent and in conjunction with other archaeological information) how a specific population lived. This specific type of analysis can also be very telling in revealing what sort of stressors (biological, environmental, and social) may have been exerted upon specific populations.

It should be noted, however, that the literature examined will not be solely confined to a view of Central America and the Maya area, but will draw on methodology and conclusions that have emerged from a wide range of different archaeological (and osteological) investigations, as well as from the field of modern dentistry.

There is a great deal of information that has been disseminated related to LEH and as such there will be some areas

that will not be touched upon, but all of the major aspects of modern LEH research will be reviewed, with particular emphasis placed upon what specifically the presence or absence of linear enamel hypoplasia can tell archaeological investigators. This background material will have special relevance in the following chapters, in which we will examine the actual data collected from Santa Rita Corozal.

In order to facilitate discussion of the literature it is necessary to further define LEH as it is presented in one of the primary sources for this review and the associated thesis project. Buikstra and Ubelaker (1994:56) define enamel hypoplasia as:

....deficiencies in enamel thickness which may be caused by three phenomena; systemic metabolic stress, hereditary anomalies, and localized trauma. Caused by defects in matrix secretion....

Systemic metabolic stress has historically been one of the most important and widely accepted causes of enamel hypoplasia and is usually treated as a more general indicator of many different types of stress (Larsen et al. 1996:162). However, by examining the patterns of stress more closely in a given sample it is possible in many cases for the type of stressor affecting the growth of enamel to be isolated and defined even further.

One of the stressors examined is the quality of foodstuffs that were consumed on a regular basis. This results in a more complete and accurate picture of what factors were actually interrupting the growth of an individuals' enamel and to what degree these factors were affecting growth. The researcher can then come up with a more specific conclusion about the life style of the individual or group during childhood, which is when LEH forms. This is more beneficial than just stating that the individual was experiencing a number of possible stressors depending upon the specific environment. Buikstra and Ubelaker (1994:56) state that stressors,

....Such as malnutrition and infectious disease can produce abnormal enamel during dental development. Studies of living people indicate that the form and frequency of developmental disturbances such as enamel hypoplasias and opacities reflect health status and diet quality. Since enamel formation is cumulative, a permanent record of juvenile developmental disturbances is available through the study of enamel defects.

Hereditary anomalies can also be a factor in the appearance of hypoplastic defects on an individual's dentition, although this cause is typically far less frequent than that of metabolic stress (Hillson and Bond 1998:89). However, it is an important avenue of inquiry and should be briefly covered to provide a complete and accurate picture of the current state of LEH research.



Hereditary anomalies are the result of a genetic mutation that has resulted in poor, uneven or incomplete growth of the enamel during development. While this information may be more useful to a researcher studying the genetic history or lineage of a particular population, it is not necessarily a good indicator of diet or types and levels of stress within the population being studied (Buikstra and Ubelaker 1994:56). Although not necessarily relevant to dietary or stress analysis, it should also be noted that some past genetic studies have demonstrated that disruptions in the growth of enamel occur only during the heightened period of metabolic activity that can be seen during the early developmental years (Weyers 1977:243).

Weyers' (1977:244) data also shows that females exhibit more indicators of hypoplasia than males; this is interesting (if not directly applicable to this thesis due to the lack of males for comparison) because the sample used in this thesis is composed of women and juveniles. The use of hereditary data would be interesting to examine in any analysis of LEH in order to determine whether or not there is in fact an increased frequency of hypoplasia in female individuals over males and what sort of ramifications such a division would have in relation to a specific subset of the population.

The possibility of trauma being the cause of LEH, rather than biological alterations, can seriously skew the resulting conclusions that will be based on faulty or inaccurate interpretation. Typically, hypoplasia resulting from trauma will only be apparent on the one or two teeth that were affected by the injury (Buikstra and Ubelaker 1994:56). Enamel hypoplasias caused by trauma are different in appearance compared to those caused as the result of metabolic changes, which are systemic. These changes result in the cessation of enamel growth throughout the dentition in its entirety, rather than in just a single isolated tooth, although there are always exceptions to this. Any injury that may occur during the actual developmental span of the dentition can directly affect and alter the resulting morphology of the teeth, because many injuries, especially severe ones, alter the delicate balance of the body's various systems. An imbalance such as this during the developmental years of a child can often result in morphological manifestations that appear after the injury, as in the case of LEH (White and Folkens 2000:473).

It has also been suggested that the occurrence of a severe childhood trauma may manifest itself in both LEH and the appearance of Harris lines in the long bones (McHenry and Schulz 1976:507). Unfortunately, well preserved long bones that may

show Harris lines do not exist in this sample group at Santa Rita Corozal. However, McHenry and Schulz (1976:509) concluded that there was no meaningful correlation between enamel hypoplasia and Harris lines in the long bones of their sample. It should also be noted, however, that the authors do state that this may be the result of the different ways in which bone heals and repairs itself and the slower and less complete way in which tooth enamel begins and ends its periods of growth. While not necessarily useful within this sample group it may be useful to recognize that there may in fact be a correlation, however slight, between Harris Lines and LEH.

#### Enamel Formation

During amelogenesis, which is the process by which enamel is grown during its developmental stages, the formation of enamel begins at the occlusal apex (the future location of the cusps) of each tooth crown with the secretion of enamel by ameloblasts (Lovell and Whyte 1999:69). Following this the new enamel works its way down the tooth and ceases growth at the cervical enamel line, where the root of the tooth meets the crown (Lovell and Whyte 1999:69; White and Folkens 2000:115). Linear enamel hypoplasias occur when there is an interruption in

enamel formation during this process. This interruption forms a line, a series of pits, or a single groove across each individual tooth (such as in the canines depicted in Figure 6) that can vary in width and position in relation to the age of the individual (and the specific stage of crown growth for each tooth, which varies) and the severity of the interruption (White and Folkens 2000:473; Buikstra and Ubelaker 1994:56).

While linear enamel hypoplasia is often visible to the naked eye (termed a macrodefect) there is a similar defect that occurs on a smaller level that can only be observed by sectioning the tooth and examining it under a microscope (Wright 1990:26). These features are called Wilson Bands (microdefects) and are the most prominent of these minute enamel malformations (Wright 1990:26). Essentially Wilson Bands result from the same type of stress that causes LEH, only they occur on a different scale (Wright 1990:28). Wilson Bands are not commonly used to diagnose stress in prehistoric archaeological remains because it requires sectioning the tooth (and thus damaging or destroying it) in order to properly examine it (Wright 1990:26). Wilson Bands will show up under a microscope as thin brown striae. They indicate where there was active enamel formation at the time the stress occurred, in the same way that LEH presents on a larger macroscopic scale.

It should also be noted that the analysis of these morphological features, as in many areas of osteological research, can be influenced by the perceptions of the observer. One individual may score and record a set of hypoplastic features on a tooth differently than another (Danforth et al. 1993:297), but strict adherence to a specific set of standards and protocols can reduce the number of misidentified features that appear in a specific projects final data set (Buikstra and Ubelaker 1994:56). This same sort of variation can also occur when calculating the age at which a LEH episode occurred, and is examined by Ritzman et al. (2008) in very useful detail.

Hillson and Bond (1998:91) have shown that through microscopic examination of dentition it is possible to observe the fine details of crown growth that are part of the formation of hypoplastic anomalies. The authors describe the various forms of enamel hypoplasia (furrows, pits, and exposed-plane-form) and detail how frequently each type occurs in the human dentition (Hillson and Bond 1998:96-101). The most common form of hypoplasia is the furrow, which is the type that can be seen in the dental samples used in this thesis, as well as in the other works examined in this chapter. Furrows can typically be divided into three separate parts, an occlusal wall, the floor, and the cervical wall (Hillson and Bond 1998:98). Furrows can typically

be observed under natural light with the naked eye, as is described for this thesis in the methodology chapter.

Studies have demonstrated differences between the frequencies of hypoplastic defects in relation to different teeth. For example, Goodman and Armelagos (1985:479) have shown that in a sample of teeth from thirty prehistoric Amerindians the frequency of hypoplasias is higher in anterior teeth than in posterior teeth. This same study has also shown that there are additional variations that occur between different individual teeth that can be correlated with the relative age of the individual. The peak frequencies of this study range from 2-2.5 years in incisors, which begin to develop earlier in life, to 5-6 years in the second molars, which tend to develop later in life (Goodman and Armelagos 1985:485). Ash and Nelson (2003:45) give slightly different figures of 4-5 years for incisor crown completion.

The recognition of these variations in frequency is important to any project that will compare evidence of enamel hypoplasia from one tooth to another, as in the comparison between the incisors and second molars above, because the differences in the developmental time frame between disparate teeth can affect the overall interpretation of when interruptions in growth began and when the subsequent

hypoplasias occurred. All of these morphological manifestations that have been described above can tell volumes about the environment, diet, and general stress levels of the individual being examined.

Linear enamel hypoplasia is an excellent indicator of the early developmental medical history of an individual as the physical manifestations of enamel formation are in many cases the only indicators that still exist within the archaeological record. This is because the enamel of the permanent dentition initially forms during childhood and remains essentially unmodified throughout the duration of the individuals' life span (Starling and Stock 2007:522). After data has been collected from a specific sample of teeth and the results have been analyzed then there is much that can be learned, depending upon the history of the particular area and also upon the amount of comparative archaeological material that can be found at the site being studied, because teeth can tell us only so much without being framed within the proper archaeological context.

There have been studies, such as the work conducted by Keita and Boyce (2001:733), which address how urbanization has affected the growth of enamel. The archaeological community, as a result, has also learned a great deal about the diet and general health of various peoples who lived in early urban

areas. This can reveal useful information not only in an archaeological sense, but it can also give researchers insights into what type of health problems can be expected in more modern cities and in developing countries around the world.

Other studies, such as the one carried out by Cucina and Iscan (1997:213), can lead to intriguing conclusions about the specific socioeconomic status of an individual or a group as a whole. This is of particular use for any archaeologist because it can provide confirmation of a sort for other related artifactual evidence that has been recovered. Also, in situations where other evidence may not be available the information gleaned from LEH analysis is, while not perfect, a solid theoretical position upon which to begin to draw further conclusions about the society or sample group being studied.

LEH data can also be used to discern past historical events that may have occurred throughout a large population, although to draw such inferences one must be careful to use an adequate sample from across the entire population. These may include a severe and widespread famine, which would leave traces of poor nutrition in the growth of enamel forming in younger individuals across a wide spectrum of a particular society at a single point in time (Lovell and Whyte 1999:72). This may also provide information relevant to the previous point in that a more



nutritious diet during a time of wide spread famine or drought may be a signal (that should be used in conjunction with other archaeological information) that those specific individuals were members of a higher social or economic tier within the community.

This population wide patterning can also be observed in samples from early agricultural Florida and Georgia in North America. Larsen et al. (2007) demonstrated that the early populations of these areas show a distinct change in diet between the individuals living in Florida and those living in Georgia. This is shown through frequency changes Wilson bands as well as other dietary shifts that can be observed between individuals living in different time periods. These data are extremely useful because unlike Mesoamerica or many other parts of the world the preservation is even poorer in these locations. In addition there was also very little ceramic or stone working technology being exploited during the early periods of agriculture in the American South-East. As such, this dietary evidence, gathered from archaeological dental material, is some of the only evidence available for reconstructing these cultures.

It should be recognized, however, that while all of the previous results of enamel hypoplasia research are indeed

extremely useful, the most common usage of hypoplasia data is as a comparative tool for examining differential levels of physiological stress in archaeological populations, as well as in modern human populations across the world (Cucina 2002:283; Boldsen 2007:59). Another unrelated, but fascinating, aspect of LEH research is the analysis of enamel hypoplasia and its application to the study of our primate cousins. This is demonstrated by the studies carried out by Lukacs (2001:199), as well as in the analysis of our early human ancestors (Skinner 1996:833; Guatelli-Steinberg et al. 2004:65). Studies such as these can give clues to the diet of past primates, as well as modern ones, and can tell us not only about the general stress levels of a specific population, but also about the environment in which they lived. The effects of disease are also examined, which have been observed to hinder enamel growth and development.

The presence of disease, particularly during childhood, can also be seen through the analysis of LEH, although there is no root medical cause that can explain every incidence of LEH (Goodman and Rose 1990:59). However, it has been demonstrated that enamel hypoplasia is associated with several childhood diseases (Ortner and Putschar 1981:268), such as congenital syphilis, rickets, and tuberculosis; with the incidents of

tuberculosis being observed by Knick (1982:131) in a sample from Pre-Columbian North America. These indicators of past disease can be extremely useful not only for the archaeologist, but also for medical and epidemiological researchers who are attempting to locate the common origin of diseases and thus give the medical community clues about new theories pertaining to these diseases and their histories. There is also the possibility of water-borne pathogens causing stress in infants during the weaning process is also an intriguing possibility that will be discussed in alter chapters.

Carbon and oxygen stable isotopes in dental enamel are also an avenue that should be explored more fully. Work by Wright and Schwarcz (1998) has explored the possibility of examining diet and weaning age through the monitoring of carbon and oxygen stable isotopes in the enamel of adult individuals. This is particularly useful because it can serve a complimentary role in the examination of the overall diet of a population during adolescence, specifically during the critical weaning period in which a child is undergoing a shift in overall nutrition. The use of stable isotopes has long been a tool used by archaeologists for the study of the diets of ancient peoples.

Wright and Schwarcz's study examines individuals from Kaminaljuyú in Guatemala. An important difference between this

study and other work discussed in this thesis is that the study of the dentition is primarily concerned with the molars (Wright and Schwarcz 1998:4). The results of this study by Wright and Schwarcz show that while Maya children at Kaminaljuyú began eating solid food at a young age they continued to breast feed for much later than has typically been thought (Wright and Schwarcz 1998:4). This may have more direct applicability to this thesis, as the calculated ages for LEH episodes at Santa Rita appear to occur around the ages when weaning may have taken place for the Maya of the Postclassic period. This study by Wright and Schwarcz suggests a long and drawn out introduction to solid foods and as a result shows that the disruption of enamel growth most likely would have occurred less frequently or in a smaller percentage of the population. However, it should be noted that just the weaning process does not always result in malnutrition. It is simply a change in diet that is stressful and can introduce different foods and pathogens that the individual has not experienced before, resulting in systemic stress. This stress can then present on the dentition as LEH.

While the use of stable isotope analysis was not undertaken in the studies previously discussed or in this thesis it is important to recognize it as an available option for cross-comparisons between different methodologies. The usefulness of

stable isotope analysis in the study of LEH is that it provides another viewpoint for determining the root causes of the stressors that result in the formation of enamel defects in the dentition. This is particularly true within the study of LEH because so many different forces can cause an LEH episode and being able to eliminate other possible causes (diet, weaning, etc) through different methodologies is highly useful. Future Maya-specific isotopic studies will be discussed in the next section.

The times at which the crown of the permanent dentition is fully formed and its relationship to LEH, has been studied extensively for a number of years. Ash and Nelson (2003:32-53) state that the crown of the permanent dentition is typically completed around 4-5 years of age. However, it should be noted that not all of the individual teeth finish their enamel formation at the same time. These variations in tooth formation times are also discussed in more detail in Malina (1998).

For both upper and lower incisors the age range for crown completion is 4-5 years. For the upper and lower canines the age is 6-7 years, with the first premolars being completed at around 5-6 years (Ash and Nelson 2003:39). The second premolars tend to finish their crown growth even later at around 6-7 years. The molars vary more widely in their dates of crown completion, with

the first molar at 2.5-3 years, the second at 7-8 years, and the third much later at 12-16 years of age. Being aware of these crown formation times allows us to interpret the age at which individual episodes may have occurred. These ages will typically be presented as a range, as individual variability necessitates a broader view of when these episodes of stress occurred.

#### Linear Enamel Hypoplasia in the Maya Area

Studies within the Maya area related to LEH have been undertaken by numerous scholars either as a stand-alone project or as a compliment to other archaeological analysis. Differences between these techniques and those utilized in this thesis will also be explored, as well as any major differences that may be present in the results of a selection of studies isolated to the Maya area.

Mendez Colli et al. (2009:344) describe a study of LEH at the prehispanic Late Classic period site of Xcambó, located on the northwestern coast of the Yucatan. What makes this settlement compelling is that the authors state that there were in fact no elite Maya living at this site, at least in the traditional sense of the term 'elite'. Studies at the site have thus far shown that this population was somewhat taller in stature than more inland populations (Mendez Colli et al.

2009:345). This is most likely a result of the large and diverse quantities of seafood that the residents of Xcambó consumed. It also appears that this population remained healthy despite a host of parasites and illnesses that were present in the local environment (Mendez Colli et al. 2009:346). These environmental conditions also served to isolate the residents of Xcambó for much of the history of the settlement (Mendez Colli et al. 2009:346). A study of LEH is particularly interesting within the context of this population because it may shed light on aspects of this seemingly well fed population during their more vulnerable developmental years.

The methodological approach used in this study closely mirrors the study undertaken for this thesis. Of the 600 remains, only the remains that contained dental material were used. This resulted in a sample size of 275 individuals, 208 adults and 67 sub-adults (Mendez Colli et al. 2009:347). Also eliminated from the sample group were dental samples that were either too badly damaged or poorly preserved to make an accurate scoring of LEH possible. The teeth were then examined visually with relatively low power hand magnifiers (Mendez Colli et al. 2009:347). As in this thesis there was a distinct preference granted to the incisors and canines, as these are the teeth where LEH is most commonly present. Another similarity lies in

the use of one tooth showing signs of LEH to label that individual as having suffered from a stressful incident.

The results of this study showed that there were an extremely high percentage of individuals that presented with signs of LEH. Of the 93 females that were included in the study every individual showed signs of LEH on at least one tooth (Mendez Colli et al. 2009:348). Equally remarkable is the fact that of the 67 sub-adults that were examined all of those individuals showed signs of LEH as well (Mendez Colli et al. 2009:348). This is markedly below the approximately 53% of the sample from this thesis that showed signs of LEH. Also of note is the fact only one of the adult males out of the 108 examined was described as showing signs of LEH (Mendez Colli et al. 2009:348). It is possible that the LEH examples in this study were affected by some sort of genetic anomaly that caused the abnormally high percentages discussed above.

The stress which induces LEH may be a result of any number of phenomena, including social status (differential access to nutritious consumables), climate change (changes in availability or quantity of traditional foods and annual droughts), and other environmental factors (pathogens from water, insects, etc). It is possible that this higher percentage of individuals is a result of Xcambó's location in a more disease prone area, which



may have had more of an effect on younger individuals who were still in the process of gaining an immunity or resistance to the wide variety of bacteria that were present in the environment and water supplies. It is also possible that gender inequities were taking place. This may suggest that male children might have been treated differently (fed more adequate food during their critical developmental stages) than female children. The authors also note, importantly, that LEH may not always be the best predictor of social stability or status, primarily due to the contradictory evidence their study has shown of a healthy population enjoying longevity and plentiful access to food, while at the same time showing very high rates of hypoplastic defects.

Wright (1997) examined childhood health during the decline of the Classic period, through analysis of a skeletal sample from the Pasión region of Guatemala. The primary purpose of Wright's study was to reexamine the previous studies of malnutrition during childhood using more advanced methodologies. Wright's sample group contained 160 adult individuals. The methodological approach used in Wright' study is similar to this thesis in that teeth that were unsuitable for scoring were set aside and not used in the examination of LEH in the sample.

In contrast to the previous study by Mendez Colli et al. (2009) the enamel defects observed by Wright (1997) were further divided into several different categories, including LEH, Major Growth Arrests (MGA), shallow broad depressed zones, and pitted enamel (Wright 1997:238). However it should be noted that the vast majority of recorded defects are in fact representative of LEH. One of the major differences between Wright's study and this thesis as well as the previous work by Mendez Colli et al. (2009) is that each tooth was divided into discrete sections and only sections that could be observed on all teeth of the sample group were scored, as opposed to scoring hypoplasias more generally as either present or absent on each tooth (Wright 1997:238).

The results of Wright's study show that approximately 59% of teeth analyzed show signs of, at a minimum, one stressful event per individual (Wright 1997:239). The results also show that the occurrence of these stressful events remained relatively stable over time and that there was not a marked increase over time, which would suggest a population suffering from increased malnutrition or stress (Wright 1997:239). There is also a slight indication that the appearance of LEH was beginning to occur at a progressively younger age (Wright 1997:241). Wright concludes by stating that the evidence

supplied by LEH of childhood stress does not necessarily support the general deterioration of health as being a factor in the decline of the Classic period.

Earlier studies by Saul and Hammond (1974) on linear enamel hypoplasia from the ceremonial site of Lubaantún show that other examples of dentition collected from the Maya area (and in this case Belize specifically) demonstrate that LEH has been previously observed on teeth from a ritual context. A small cache of teeth dating to the Late Classic period was uncovered in a very small area located in the fill of a low southern facing wall that was atop a large stone faced platform (Saul and Hammond 1974:124).

It is clear that this deposition was intentional as no other osteological remains were recovered in the immediate area and the teeth were clustered tightly together and consisted of the dentition of two individuals, fifty-nine teeth in total (Saul and Hammond 1974:124). Both individuals were aged approximately twenty-five to thirty-five years with one being male and the other female (Saul and Hammond 1974:124). Both showed evidence of a disruptive event that resulted in the formation of LEH. This disruptive event appears to have occurred at approximately three to four years of age, which would seem to correlate with what the authors describe as the typical weaning

age of Maya children at the time of contact (Saul and Hammond 1974:124). This weaning age will become more relevant when the results of this thesis are examined in the following chapters. The female individual appears to have suffered a much more severe episode of LEH, with the male suffering from a more minor event.

Saul and Hammond (1974) conclude that these individuals were most likely members of the lower tier of the elites living at Lubaantún. It is also suggested that this cached dentition may have been removed postmortem and that these two individuals may have also been man and wife based upon their similar age. It is also important to note that the authors do not believe that these individuals were in any way 'sacrificed', but that they did in fact die of natural causes.

This rather unique cache is certainly fascinating and, while from a different context and earlier time period, it holds some similarities as well. The association with these individuals with some form of ritualized activity (whether post- or anti-mortem) is similar to the ritual context of several of the interments from Santa Rita (see Table 1). While the exact nature of these rituals is certainly different, as the remains were deposited in wholly different manners, there is still a correlation between the presence of ritual activity and LEH. The

association of these individuals with a lower level of the elite society may also correlate with the individuals recovered from Santa Rita, who were located in association with a large platform group that was most likely home to the upper tier of Late Postclassic period Maya society at Santa Rita.

The presence of a direct female to male comparison within the context of hypoplastic analysis is also of relevance. The male individual represented in the Lubaantún cache presents with a much milder form of LEH, while the female teeth are more drastically affected. This is a compelling comparison because there are no adult males present in the Santa Rita sample used in this analysis, and as such there is no basis for direct comparison to see if LEH does in fact present more or less severely on males than females at Santa Rita without additional review of skeletal material from other SRC contexts. While, as stated above, these two samples from Lubaantún and Santa Rita differ in a number of ways, it is also an excellent comparative tool for examining this difference between the sexes in regards to LEH severity.

Work conducted by Hammond et al. (1975) also demonstrates a relationship between the elite of Maya society and LEH. While this study is less focused upon linear enamel hypoplasia specifically there is a great deal of information that can be

inferred. This work is related to a Classic period tomb that was uncovered at Lubaantún. This tomb contained the remains of fifteen adults, all of whom were most likely related (Hammond et al. 1975:64). Of these seven were young adults (3 females, 2 males and 2 unknown), and eight middle aged adults, consisting of one female, two males, and 5 unknown (Hammond et al. 1975:64). The only surviving osteological remains in relatively good condition were the teeth.

These individuals were sexed based upon the sexual dimorphism of the dentition, a technique which was also used in the initial examination of the teeth included in this thesis from Santa Rita Corozal to help confirm in-field identifications of sex. The degree of wear on the dentition was also used by Hammond et al. (1975:64) in order to age the individuals. The examination of the dentition from Santa Rita relied primarily upon general age estimates (i.e. adult/sub-adult) provided in the original field reports by DZ Chase (1982). However, wear on the Santa Rita dentition was also used as a confirmation of age during the examination of the sample in this thesis.

The Lubaantún sample demonstrated a very high percentage of LEH within both the tomb and the total dental collection of the site as a whole. Within the tomb itself fourteen of the fifteen individuals recovered showed signs of LEH, with the entire

dental record of the site showing that nineteen of the twenty-four individuals excavated also demonstrated signs of linear enamel hypoplasia (Hammond et al. 1975:64). The authors also state that these numbers are very similar to Altar de Sacrificios, 37 out of 40, as well as Seibal, 36 out of 39 (Hammond et al. 1975:65). This data from Lubaantún seems to suggest that the discovery of LEH among the Maya elites is not necessarily an unusual occurrence with several possible explanations, which will be discussed in the sections below.

At the sites of Caracol, Santa Rita Corozal, and Tayasal, studies by DZ Chase (1997) have helped to define what exactly can be inferred about Maya society through the study of skeletal remains, a topic which has a great deal of relevance not only for this thesis but also for interpreting the previous works that have been examined in this chapter. Chase (1997:18) describes some of the difficulties associated with these samples:

For late facet Late Postclassic Santa Rita, the time period for which we have the largest skeletal sample as well as ethnohistoric information that can be correlated with this estimated population peak, only .002% of any contemporaneous population was recovered archaeologically. ....Thus, our skeletal samples are extremely small, in spite of all the excavation that has been undertaken. The major implication of these figures is that interpretations made from such archaeological samples with regard to health, age of death, and population characterization may suffer from significant sampling errors even if the

percentages of relative population derived from both structural counts and skeletal individuals is equivalent.

This perspective on the problems associated with attempting to determining larger population wide trends of an entire site based upon a small sample size is one that is of particular concern for this thesis, as the sample selected for analysis from Santa Rita represents a very small percentage of the overall population, and as such cannot necessarily be used to accurately interpret site-wide forces of general stress. It can, on the other hand, be used to interpret (with the aid of contextual information) the general state of stress for the specific sample being examined (individuals from Platform 2 in the case of this thesis). However, this is a point that will be restated a number of times throughout this work, as it is an important check against the urge to base site-wide discussions on data that may not necessarily be accurate for that broader level of interpretation.

Chase (1997) examined dental samples from the site of Caracol in south-western Belize. Of the total skeletal sample (as of 1997) linear enamel hypoplasia is present in only sixteen percent of the individuals sampled, and is in fact the most common affliction seen in the burial records (Chase 1997:24). In contrast to this figure there is only one individual from the



site of Tayasal that demonstrates any degree of hypoplasia whatsoever (Chase 1997:24).

Chase (1997:27) concludes by stating that there is a great deal of information that can be learned in regards to individual sites (and variability throughout the Maya Area) through the examination of skeletal remains, but these studies should also work in concert with other archaeological material. Several related problems regarding osteological interpretation are also discussed and include a wide range of different methods of describing and reporting osteological remains. This creates further difficulties for comparative analyses, yet another aspect that should be kept in mind, particularly for the Santa Rita sample analyzed here. Particularly due to its small sample size of 13 individuals, as opposed to some much larger sample sizes seen in other studies examined in this chapter.

Saul and Saul (1997) also offer an excellent discussion on the interpretation of osteological material and on linear enamel hypoplasia in particular. While in the context of the Preclassic site of Cuello in northern Belize, there is still a good deal of interpretive information that can be learned, even if direct comparison is not permissible. The authors describe the sample group as being composed of 96 individuals, with hypoplasia tending to appear at around three to four years of age (Saul and

Saul 1997:34). As stated by Saul and Hammond (1974:124) as well, this is thought to be the typical time at which Maya children were weaned from their mothers. This is applicable to this thesis because the mean age at which LEH appears on the sample dentition is 3.5 years of age, suggesting a possible relationship of stress related to weaning.

As in the methodology of this thesis, the authors state that the presence of linear enamel hypoplasia in an individual requires the presence of only one incidence (a single tooth) in order to count that individual as being affected. The percentage of individuals showing signs of hypoplasia at Cuello is similar to the percentage for this thesis (53.8%) and several other works discussed in this chapter, 59% (Saul and Saul 1997:34). This is composed of 57 individuals from the total number of 96 interments that were included in the sample group (Saul and Saul 1997:34). In general this sample group tends to demonstrate a higher frequency of hypoplasia in females than in males, which is similar to the majority of the other studies examined here. Of note is the presence of two individuals that are most likely members of a higher social group, as suggested by the artifactual evidence (Saul and Saul 1997:49). One of these individuals did exhibit signs of LEH as well as some degree of calculus and other caries, while the other possessed none of

these (Saul and Saul 1997:49). This pair of high status interments is an excellent contradictory microcosm for the entire discussion of this section.

The variability of the overall health and oral hygiene of the Maya (in this case the elite) is quite unpredictable. The presence of two related interments from roughly the same time period and of roughly the same social status show that while the study of LEH is certainly worthy and fascinating it still must be accompanied by comparative studies in order to fully describe the individual or sample group. It also serves as yet another warning of drawing broader comparisons across the Maya area in relation to status/stress and LEH, and even within a specific site itself.

Work conducted by Storey (1997) at Copan has examined osteological material (and dental material in particular) from a sample of high status individuals that lived in an elite compound during the Late Classic period. This study examines the pathology present on the skeletal remains of these individuals and also makes further inferences pertaining to the general health of this elite group of Maya. Storey (1997:117) states that dental defects such as LEH can provide information about the socioeconomic status of the sample group. However, the author also states that while this information is useful there

are a number of criticisms of applying skeletal analysis to social interpretation because of differences in demographics (Storey 1997:117). Storey argues that while these ideas are important it should not completely preclude these types of interpretations because these possible errors are often addressed within these studies with this caveat being clearly stated (Storey 1997:117).

The sample group in this study consisted of 264 individuals, of which 122 were sub-adults (Storey 1997:119). One of the advantages of this sample is that it does include a wide range of individuals, from a variety of age groups that are both male and female (Storey 1997:119). Out of the total sample group thirty-two sub-adults were chosen to be studied, this is due to differences in the state of growth of the permanent dentition and the likelihood of enamel defects being present (Storey 1997:119). These sub-adults were aged based upon the standards of dental formation and eruption (Storey 1997:119). This study separates hypoplastic defects into a variety of different categories aside from linear enamel hypoplasia and defines each type of defect quite specifically, a step that has not often been taken in many of the other studies examined here. This is particularly useful in the sense that it sets forth some very definite standards for what type of defects are going to be

discussed and outlines the definitions for each. This can be particularly useful for individual readers who may not be totally familiar with the terminology used in such articles and allows them to still interpret and understand the data reliably.

The results are broken down into one and two year old age groups, with children older than 2 being examined separately. Storey concludes by stating that all of the individuals in the sample group exhibited some sort of dental defect and that the implication of these results is that these are the result of both the environment of Copan and cultural context of these sub-adults (Storey 1997:125). One of the most important elements of this study is the fact that despite the relatively elite status of these juveniles they still showed a high number of dental defects. This demonstrates that these children were still suffering from periods of stress despite the supposed sheltering effect that their elite status should have provided them. This seems to correlate with previous studies that have shown that elite status does not necessarily preclude an individual from being affected by a wide variety of different stressors.

In Whittington's dissertation (1989) at Copan there is a great deal of information dealing with the correlation between demography and diseases amongst the commoner population of this important Classic period site. Whittington (1989) states that

the sample group used in this dissertation may not accurately represent the total population of Copan, but that if these limitations are clearly stated that the conclusions can still offer a great deal of relevant information regarding health and status among the Maya.

This study demonstrates a relatively high percentage of dental defects as demonstrated by a correlation between the number of hypoplasias and caries among this low status sample (Whittington 1989:369). It may be likely that one of the major causes of these hypoplasias was a dietary deficiency, specifically a lack of proteins, calories, and B-complex vitamins (Whittington 1989:370). Whittington also observes that the high frequency of LEH was a result not of a single event, but rather of a number of high stress episodes that occurred at numerous times throughout a child's early life, suggesting that this period of time was particularly stressful from a dietary and developmental perspective (Whittington 1989:371).

However, it should be noted that while these episodes of stress occurred quite frequently, it did not prevent the vast majority of individuals from growing into adults, but it is also possible that there were other more lasting effects that plagued these low status individuals throughout their lives (Whittington 1989:372). It should also be noted that there was shown to be no

significant difference in the frequency of stress defects between the sexes, a correlation (leaning towards more defects in females) that can be seen in other studies examined here. This may be true at Santa Rita, but the current sample does not include adult male dentition, so no such conclusion can be made. There are small differences that suggest that male children may have been weaned at an earlier time than females, which contradicts other studies conducted in the Maya area on the topic of weaning ages.

Whittington also makes a compelling point in that there is a relationship between the location of the individuals within the site of Copan and the frequency of hypoplastic defects they experienced. Individuals that lived within the site center appear to have undergone more stressful episodes and tended to wean their children earlier than those individuals living outside of the site core (Whittington 1989:376). Whittington concludes by stating that both poor skeletal preservation and a small sample size were factors in this study, a problem that is shared by a number of other studies discussed here, including this thesis.

Further work by Whittington (1999:151) examines the dentition of the "lowest socioeconomic level of Maya society at Copán". Whittington describes studying the commoners as being

more beneficial for examining the environment and society than forming an interpretation based solely on the osteological remains of the elite. This is primarily because the lower levels of Maya society were not buffered by status-based networks of exchange and redistribution and were more susceptible to outside conditions, which can be observed in their overall level of nutrition and health (Whittington 1999:151).

148 individuals from the lowest level of society were selected for this study from Copan. As in the study undertaken for this thesis at Santa Rita Corozal, Whittington's methodology only selected dentition that possessed the entire crown so that an accurate comparison between teeth could be made (Whittington 1999:154). Samples that were missing a section of the crown or were too poorly preserved to be accurately scored were placed aside and not included in the analysis. The dentition was aged based upon overall dental development, tooth eruption, and size seriation (Whittington 1999:154). Sex was assigned based upon skeletal analysis (as in the Santa Rita sample) and upon multivariate statistics (Whittington 1999:155).

As in the previously discussed studies examined there is a distinct difference between the presence of caries on females as opposed to males, with the frequency of caries being 26% for females and 14.3% for males of the same low status origins



(Whittington 1999:158). Another major point discussed by Whittington is that there is a difference (though slight) between individuals from urban and rural areas of the Copan Valley. Rural samples demonstrate a higher frequency of caries at 20.5%, while urban samples are slightly lower at 16.7% (Whittington 1999:159). While fairly negligible, this difference is also quite useful as a comparative tool for different types of commoner populations in different areas of the same site.

The author believes that this is primarily due the fact that both the individuals from Copan and Ontario practiced horticulture, however Whittington does note that there are also some important differences between these two samples, so a direct comparison should only be attempted with caution (Whittington 1999:161). Of particular relevance for this thesis is the extremely high rate of linear enamel hypoplasia, one-hundred percent in fact, among the sample of individuals from Copan (Whittington 1999:161). The most severe examples appear to be present on the canines from this sample, which would also seem to correlate somewhat with the Santa Rita sample examined here (Figures 10-11; Table 2).

Whittington concludes that around the time of the collapse at Copan there was a great deal of environmental stress affecting the lower levels of Maya society, which is supported

by the overall frequency of linear enamel hypoplasia and other evidence such as the frequency of anemia. This study offers an excellent comparison when added to the other works examined in this chapter, primarily due to its strict focus upon commoners. However, it should also be noted that the environment of Copan differs in many respects from that of Santa Rita and any direct comparison between the two should take that environmental difference into account. Specifically the impact of large quantities of high quality resources from the sea that were enjoyed by the residents of Santa Rita, a privilege that the lower classes (and even the upper classes) of Copan likely did not enjoy with a great deal of frequency.

Further work at Copan by Storey (1999) examines whether or not a lack of proper nutrition was a contributing factor in the collapse of Copan after the Terminal Classic period. In contrast to the sample group used in this thesis from Santa Rita, Storey examines only adult individuals, which were sexed using the standard methodologies of cranial and pelvic examinations (Storey 1999:171). The individuals composing the sample group are believed to have been related to a high-status lineage, despite a great deal of variation in the elaborateness of the interments and tombs uncovered (Storey 1999:171). As a result of this Storey has divided these individuals into different

classifications based upon the nature of their interment. This is in recognition that there may be a range of individuals from different levels of social status buried in a single location.

This is a possibility that holds a great deal of relevance in regards to Santa Rita, which contains a number of interments within a high status platform group. However, many of the females recovered from SRC Platform 2 are likely related and thus members of the same social tier. It should also be noted that Late Postclassic burials do not always contain offerings, and a dearth of substantial grave goods may not necessarily indicate a lack of status (D. Chase, Personal Communication, 2010). Storey also states that variations that appear within the different subgroups of the elite in this sample at Copan are more likely to be related to general environmental conditions and nutrition rather than other causes, such as genetics (Storey 1999:173). In regards to LEH there was again a slight trend towards more indications of hypoplasias on females rather than males, but this is only apparent in a single subset of the elite population, otherwise there was a relatively equal distribution of LEH episodes between both males and females (Storey 1999:175).

This differs somewhat in comparison to many of the previous studies examined in that there are typically much larger

percentages of females suffering from the effects of LEH than males, which agrees with the conventional wisdom associated with this dental feature. Storey concludes by stating that while in general the elite members of this sample appeared to be healthier overall, they tended to have a higher frequency of LEH than the lowest status commoners included in the sample (Storey 1999:177). However, the overall health (aside from strict hypoplasia evidence) does tend to show that elites were healthier in general than the lower classes, which is what one would expect given the elites increased access to a larger variety and quantity of nutritious consumables.

This study appears to follow the trend in the other literature examined here, in that the presence of LEH cannot be used as a classifier of status alone, but that it rather appears to have an inverse relationship with commoners tending to have fewer incidences of hypoplasia and elites having a higher frequency. However, it should also be noted that there is enough variation in the results that this still cannot be relied on as the sole indicator of status. The context of the remains still remains one of the most important indicators of the status of an individual or group.

Isotopic and dietary studies conducted at Caracol, Belize by Chase et al. (2001) follow along the same line of reasoning

as many of the previous articles that have been discussed. The author's state that information gathered from isotopic analysis should be used in conjunction with other archaeological and contextual evidence. The specific study undertaken by the authors examined the corn and protein consumed by the Maya living at Caracol (Chase et al. 2001:112). Previous studies by Gerry and Krueger (1997) have demonstrated that the consumption of large amounts of corn is the only dietary indicator of higher status, and as such can be useful in determining social ties and organization. As part of this study, 85 individuals who were recovered during the 1993 field season were subjected to stable isotope analysis.

The results of this study demonstrated that individuals had different levels of access to corn and protein sources (Chase et al. 2001:115). This (in conjunction with contextual information about their burial location) was useful in identifying what status different individuals were and where they tended to cluster within the site. The richest diets of corn and protein were found in the epicenter of Caracol, which is where higher status structures and palaces were built (Chase et al. 2001:116). The poorest diets found at Caracol were found to be in the area just outside of the epicenter, which was likely populated by workers or people involved in the production of

higher status goods, such as bone, jade, or wood (Chase et al. 2001:116).

This study demonstrates that the application of stable isotope testing can yield a variety of interesting results not only about the diet of individuals within a site but also (in conjunction with archaeological information) about where these individuals lived and worked. This tells us not only about their day-to-day lives but also about how a large city such as Caracol was organized and where different social classes were located.

Other studies by Whittington and Reed (1997) using isotopic analysis of the lower status individuals at Copan have also aided in understanding the links between nutrition and social status at this site. While this work does not specifically deal with linear enamel hypoplasia it is still related to health and diet and as such deserves some examination. This study specifically looks at the diet of the commoners of Copan. The sample group consisted of 148 low status individuals, which were examined for a variety of pathologies and defects (Whittington and Reed 1997:158). Twenty-two individuals were also subjected to stable carbon and nitrogen isotopic examination (Whittington and Reed 1997:158). In addition to these commoners a sample of elite individuals (n=57) were also examined using isotopic analysis (Whittington and Reed 1997:158). The varied nature of

this sample was specifically designed to attempt to capture a picture of the range and nature of the different diets common to a number of distinct social groups at Copan and also across three separate time periods (before, during and after the decline of Copan).

It should also be noted that a number of problems were associated with examining this osteological material, such as poor preservation that not only caused difficulties in the isotopic studies but complicated aging and sexing as well (Whittington and Reed 1997:158). The results of this study demonstrate that maize did in fact constitute a majority of the study group's diet, and that while there was evidence of deer meat being part of the diet of these low status individuals it was not particularly significant (Whittington and Reed 1997:167). The results further state that there is little difference between the classes as far as isotopic analysis of the diet is concerned, and the only major difference occurs between males and females with males consuming more maize on average than females (Whittington and Reed 1997:168).

This study suggests that while isotopic analysis is quite useful in a number of regards, it must also take into account other contextual information in order to form a complete picture of Maya society. This follows along the same vein of LEH

research in the works presented above, in that there is always a caveat mentioned in regards to the necessity of using a truly holistic approach to studies of health and status among the Maya in order to truly understand their day-to-day lives. The importance of discussing these studies that have been isolated to the Maya area is that they provide an excellent comparative tool for analyzing and providing background material for the data collected in this thesis.



### **CHAPTER THREE: METHODOLOGY**

The methodological approach used for this project is fairly simplistic and as such requires only a relatively brief explanation. The initial phase of this thesis consisted of determining what location and group of individuals would provide the most interesting contextual sample for observing instances of LEH in the osteological record. This search led to Platform 2, which contained a number of burials described as containing the remains of sub-adults and females in a relatively high status area. While this sample may not be representative of Santa Rita as a whole, it does offer insight into the general stress level of a small sample of the individuals at this site. One of the other important considerations was also that this area contained a larger concentration of sub-adult individuals that could be fairly easily associated with one another rather than a comparison from numerous small sets of remains. From the totality of Operation 6 there are 377 teeth, from a total of 13 individuals.

After the sample from Platform 2 was selected, the dental material was sorted from the rest of the skeletal material. All of the dentition from Operation 6 was removed and isolated according to specific lot numbers. The teeth were then lightly cleaned using distilled water and a sterile, soft bristle tooth

brush. This was necessary as the teeth still resided in the original boxes from the Santa Rita Corozal Project, with matrix from the excavation units covering some of the subtle details indicative of LEH. The samples were then visually inspected for evidence of LEH using both the naked eye as well as a small hand lens. The samples were then separated into each individual based upon excavation records and the number of teeth that presented with LEH from each individual were counted (Table 2). The teeth showing signs of LEH were also identified using the Primary Universal Numbering System, which can also be seen in Table 2.

Scoring and measurement of the dentition was relatively consistent with studies carried out by Goodman and Rose (1990). These measurement techniques (as well as a number of other comparative approaches) are also described and usefully compared in Ritzman et al. (2008). LEH was scored as being either present or absent on the dentition, with a single instance of LEH being sufficient to classify that individual as suffering from a stressful event. The number of LEH episodes on each tooth were also counted and included in Table 2. This was simplified in that the examples of LEH found on the dentition were, for the most part, quite apparent during the initial exam. Only dentition that clearly showed signs of hypoplasia were marked as affected. These cases clearly show a horizontal striation

running across the buccal surface of the individual tooth (an excellent example is seen in Figure 8, although not all examples appear as distinct in photographs as this particular canine).

Borderline or questionable cases of hypoplasia were not marked as affected in order to simplify the results and ensure that features other than LEH were not classified as hypoplasia, thus contaminating the results. This is because there is such a wide range of possible dental pathologies that misidentifying LEH is a constant possibility, so this practice of selecting only solid examples of hypoplasias is a guarantee (although not an absolute) of sorts that prevents misrepresentation in the resulting interpretations.

The teeth were then individually photographed using a Canon A570IS Power Shot point-and-shoot digital camera. The teeth were photographed using the macro setting and lighting was set up to give the best possible view of the LEH features, which still proved to be problematic. Scale was of course included for reader reference and accuracy. Photography of LEH features is likely one of the most challenging aspects of research in this particular area of osteological analysis, particularly for much more subtle features and occurrences of LEH.

The LEH affected teeth were then measured using a pair of sliding calipers. This was done in order to determine a possible age range (see Table 3) for the appearance of the LEH episodes. Ages for the LEH episodes were calculated using commonly accepted regression equations from Goodman and Rose (1990). These equations utilize the measurements from the LEH formation to the CEJ (mm) to calculate the age at which the LEH finished forming (further detail in Table 3). These measurements were taken from the CEJ to the center of the LEH formation on the tooth. In many cases several LEH episodes were apparent on a single tooth, in this case the measurements were taken in an order that began closest to the CEJ and gradually getting farther away. The closest measurements to the CEJ are labeled 'A' (newest episodes) in Table 3 and proceed up through 'D' (earlier episodes) gradually gaining distance away from the CEJ.

## CHAPTER FOUR: RESULTS

Of the 13 individuals examined, 8 of these were sub-adults. For the most part there did not appear to be any other severe stressful events (injuries, disease, etc) present on the dentition. It should also be noted that there did not appear to be any substantial injuries observed on the skeletal remains according to field observations of the remains in Chase 1982. This means that the cause of death for many of these individuals was likely not something that would present in the dentition (some pathologies for instance). With the exception of a very small number of caries there is little evidence of severe dental wear or abscesses. Of these 13 individuals in the sample group there were 7 that showed signs of linear enamel hypoplasia. Of these seven individuals five were sub-adults. It should be noted that all of the teeth examined were part of the permanent dentition. It does appear that many of the examples of LEH seem to have presented at a relatively young age, with a mean of 3.5 years for all LEH episodes (Table 3).

However, whether or not this is a result of weaning or some other form of stress (pathogens, drought, or another environmental factor) is not clear enough in this sample to make a determination. While it is a possibility that weaning played a role in the development of these LEH's it has also been

demonstrated that nutritional upsets, traumatic injuries, or diseases can occur at a wide variety of ages, not only during the window of 3 to 4 years of age that weaning most likely occurred (Saul and Hammond 1974:124). The injury would only have had to take place during the early developmental years of the child, from around 1-8 years for the majority of the dentition. All of these factors should be considered as possible causes rather than only isolating one, despite the problems of interpretation that this causes. In order to clearly narrow down a possible cause it would be necessary to measure a larger sample from the rest of the Santa Rita Corozal collection, covering not only Platform 2 but a sample of burials from across the site as a whole and from a wide variety of contexts.

One of the possible environmental causes of the observed LEH episodes could be an annual drought. Many individuals, most notably Individual A from SDP6E-1, have presented with LEH episodes on a near annual basis (see Table 3). While certainly interesting as a possibility it would require confirmation from further archaeological and/or climatological research in the area of Santa Rita Corozal. However, if confirmed this correlation would provide a quite remarkable way to confirm (or at least theorize about) climate change through the osteological record, rather than strictly through other archaeological or

geologic sources. For future studies it would be quite fascinating to expand the sample size at Santa Rita (while looking for approximately annual LEH episodes) and then conduct similar research at other neighboring Maya sites for comparison. Collaborative work with climatologists would also be necessary in order to determine whether or not an annual period of drought may have been occurring in the area.

Another possible source for these LEH episodes is also water related. As a result of the weaning process infants are transitioning from a diet of milk to a more adult diet of corn meal and water. This addition of water is likely to introduce pathogens into the infants system, resulting in physiological stress. Fresh water being collected in stone cisterns can be breeding grounds for a number of diseases, as well as mosquitoes and other disease carrying insects. Adults would likely possess immunity to many of these diseases due to built up resistance over time, but the initial exposure that infants experience as a result of the weaning process may cause enough systemic stress that it results in the interruption of enamel formation. This explanation would show results that occur at all times throughout the year, not necessarily annually as in a drought.

It is also important to note that it does not appear that these examples of LEH occurred from a root cause in the entire

sample group. Some LEH episodes appear to have occurred earlier in life, while others appear to have occurred slightly later in adolescence (Table 3). However, the range of ages seen in Table 3, even with a margin of error added to the calculations, suggests that whatever stressful episode occurred happened earlier in life, with a range from just over one year of age to approximately 5 years of age (Table 3). This is based upon measurements of the position of the LEH episode on the tooth, which gives us insights into when the instance of LEH appeared during the development of the individual. The hypoplasias positioned close to the cusp of the tooth will have formed before ones located further away from the cusp, following the pattern of enamel formation. The differences in tooth formation times must also be taken into account, as individual teeth form at a different rate across the entirety of the dentition (this is discussed in further detail in Malina 1998).

The adult females among the sample appear to have a relatively high degree of wear on the molars, but this is to be expected due to the fine grit stone found in processed Maya corn (and other food products) and other products. This grit is primarily a result of the use of stone manos and metates during the grinding process. Wear is typically associated with age, and can be used in order to narrow down the age of an individual to



a reliable window. There is also a high degree of shoveling apparent on a number of samples as well, with several quite robust examples. The juvenile teeth also appear healthy and strong with very little damage, if any. The only apparent indicators of stress of any kind are the seven individuals that show evidence of LEH episodes on their dentition (see Figures 8 through 20). The most robust of these examples being from a tooth recovered from Lot 36 of Operation 6, Sub-Operation E, SDP6E-1. This upper permanent canine (PUNS#11) shows a very distinct band that is a textbook example of the effects of LEH (Fig. 8). While the other dental samples included among the LEH-affected examples do show some signs of LEH, for the most part they are quite subtle and are most likely indicative of a more minor malnutrition event.

## **CHAPTER FIVE: DISCUSSION AND CONCLUSION**

There is a great deal of similarity between findings on LEH at Copan and other Maya sites and the results of this thesis. However, it should be noted that this study is dealing with a much smaller sample size than many of the works examined above. One of the major similarities is that there has not been a significant correlation demonstrated between the presence of LEH and the specific status (nutritional or otherwise) of an individual (Mendez Colli et al. 2009, Wright 1997, Storey 1999).

These results also correlate with the conclusions arrived at by other researchers, who state that studies of LEH should only be used as a compliment and addition to more holistic examinations of the ancient past (Chase 1997, Mendez Colli et al. 2009, Wright 1997, Storey 1999, Wright 1990, Wright and Schwarcz 1998). LEH can yield useful information of the overall stress levels of a population at a site, despite its lack of ability to clearly delineate ties to a specific social class. An intriguing aspect of this comparison to other Maya sites is that there are a number of environmental differences between them. As such there is variation in regards to the types of foods being exploited and the types of pathogens and environmental conditions affecting the populations. Yet despite these differences there is still the same level of ambiguity in

regards to associations between status and LEH, suggesting that there is in fact very little correlation between the two.

As indicated in the literature review of LEH, the only evidence found was present on canines and incisors, with the exception of evidence from two premolars from P6E/36 SDP/6E-1 (Figure 10 and Table 2). Premolars and molars were inspected as well to ensure that any evidence present on these teeth would be detected but, as expected, there were no signs of LEH present. This is interesting because it suggests that the LEH episodes occurred before 5-7 years of age, which is when premolars commonly complete their crown formation (Ash and Nelson 2003:45). This is supported by the data in Table 3, which shows many of the ages for LEH formation occurring several years before this time, with a mean of 3.5 years for the entire sample.

This mean age of 3.5, while from a small sample, is well within the range for the typical Maya weaning age (~3-4 years) at the time of European contact (Saul and Hammond 1974:124). This is an intriguing possibility and should be kept in mind when future studies of the Santa Rita dental material are undertaken. This transitional period when a child is shifting from their mother's (or nursemaid's) milk to more 'adult' food could possibly cause a nutritional disruption to their system

resulting in the presentation of an LEH episode. This would likely occur across all status levels, as the softer processed foods fed to small children would likely be a common nutritional theme across both the upper and lower tiers of society. It is also possible that the transition to water as the primary liquid being consumed would result in exposure to a variety of pathogens that adults would have immunity to but would place stress on an infants system, resulting in LEH formation. The possibility of approximately annual droughts in the area around Santa Rita is yet another possibility, which would explain the near-annual presence of LEH on a number of individuals in the sample. A drought event would have been a population-wide concern and would likely have affected all individuals, not just the lower classes or elites.

It should also be noted, as is described in the section on LEH in the Maya area, that there is not a clear correlation at other Maya sites between the presence/absence of LEH and the status of the individuals. It appears to cut across many different levels of status within Maya society. The literature generally tends to support this conclusion and it does suggest that utilizing LEH as an indicator of status is inappropriate. While the presence of poor nutrition may be more common in lower classes with poorer access to consistent and/or plentiful food,

there are many other stressful events or injuries that can result in LEH in individuals of any class. Thus it is impossible to say with certainty that the presence of LEH denotes a lower status individual.

The information that can be gathered from an examination of LEH is something that speaks to a group's past way of life in a way that few other archaeological sources can. This data, if interpreted properly, can lead to some interesting conclusions about how a group of people lived and what type of status they enjoyed within their own social niches. Comparative studies of diet and socioeconomic status between sites and even regions can also give hints about who may have dominated whom and what type of social status a certain group within the overall society may have enjoyed. This is because the type and quality of food that a group consumes is often an excellent indicator of overall status and general access to resources. It is also important to note that there is always the possibility of localized trauma altering the analysis of enamel hypoplasia, and as such it is important to recognize this limitation.

The application of this type of osteological research to the Maya area in a broader sense can only benefit the archaeological community as a whole. As well as other disciplines that work closely and interact with archaeologists

in the truly holistic approach that this type of research has become. It should be noted that the analysis of linear enamel hypoplasia is not the Holy Grail of osteological or archaeological research. As with all aspects of scientific research (particularly within archaeology) the data gathered from LEH research should be treated with a distinct tone of skepticism. As with all things, there are other possible causes for the appearance of LEH in the enamel of the teeth.

Further study at Santa Rita, utilizing a larger sample size from across the site as a whole may yield a great deal more comparative information, particularly regarding weaning age at this fascinating Maya site. The information collected in this thesis suggests that the majority of the stressful episodes occurred around 3.5 years of age, which while intriguing, requires further research at the site as a whole to form a conclusive argument regarding the weaning age of Postclassic children at Santa Rita Corozal.

While the most likely cause in many situations is of course a change in the diet of an individual, the other possibilities examined in this work (such as disease or injuries) must be kept in mind so as to prevent the misinterpretation of data, and thus the propagation of imprecise theories in the future based upon these conclusions. Linear enamel hypoplasia is a useful tool and

it should be explored to its fullest potential. But studies such as this should only be interpreted in conjunction with other archaeological data. The study of Linear Enamel Hypoplasia is only just beginning and in the coming years and with the rising prevalence of more advanced technology and methodologies, this avenue should provide archaeologists with a new array of data to sift through and attempt to reconstruct the past, one tooth at a time.

## APPENDIX A: TABLES



**Table 1**

Interments from Platform 2 at Santa Rita Corozal

Note: Not all burials associated with Platform 2 are listed. The Special Deposits listed are only those which contained dentition, and as such were part of the sample for this thesis.

<b>Special Deposit</b>	<b>Lot</b>	<b>Total Individuals</b>	<b>Individuals with LEH</b>	<b>Sex/Age</b>
SDP6E-1	P6E/36	5	3	Sub-Adults (one Adult Female ?)
SDP6E-2	P6E/31-1	1	0	Fem/Adult
SDP6E-6	P6E/76	1	0	Fem/Adult
SDP6E-7	P6E/82	1	1	Fem/Adult
SDP6E-8	P6E/83	1	1	Sub-Adult
SDP6E-11	P6E/87	1	1	Sub-Adult
SDP6E-12	P6E/88	1	1	Fem/Adult
SDP6F-1	P6F/53	2	0	Sub-Adult and Fem/Adult
<b>Total:</b>		<b>13</b>	<b>7</b>	
<b>Breakdown of Individuals with LEH:</b>	<b>5 Individuals with LEH are Sub-Adults.</b>	<b>2 Individuals with LEH are Adult Females.</b>		

**Table 2**

All Dentition is Permanent unless otherwise specified. Tooth Types are identified using Primary Universal Numbering System.

Special Deposits with LEH	Individuals with LEH	Number of Teeth with LEH from Each Individual	Type of Tooth (Primary Universal Numbering System)	Number of LEH Episodes on Individual Teeth (ex. PUNS # = LEH Episodes)
SDP6E-1	3	Individual A: 1 Individual B: 4 Individual C: 1	Individual A: 11 Individual B: 6, 20, 21, 22 Individual C: 6	Ind A: 11=4 Ind B: 6=2 20=1 21=2 22=1 Ind C: 6=3
SDP6E-7	1	1	9	9=2
SDP6E-8	1	4	23, 24, 25, 26	23=1 24=2 25=1 26=2
SDP6E-11	1	4	8, 9, 22, 27	8=1 9=2 22=1 27=2
SDP6E-12	1	1	22	22=2

**Table 3**

Age Estimates

Regression Equations Derived from Goodman and Rose 1990 and Ritzman et al. 2008.  
 Example: Central Maxillary Incisor Height Measured from CEJ to Center of LEH in mm.  
 Age =  $-(.454 \times \text{Height}) + 4.5$

Special Deposits with LEH	Number of Teeth w/ LEH	Type of Tooth (PUNS)	Formula And CEJ to LEH Height (mm)	Age Estimate
SDP6E-1	Ind A: 1 Ind B: 4 Ind C: 1	Ind A: 11		
		LEH A	$-(0.625 \times 1.5) + 6.0$	= 5.06
		LEH B	$-(0.625 \times 4) + 6.0$	= 3.5
		LEH C	$-(0.625 \times 5.5) + 6.0$	= 2.56
		LEH D	$-(0.625 \times 7) + 6.0$	= 1.65
		Ind B: 6		
		LEH A	$-(0.625 \times 2) + 6.0$	= 4.75
		LEH B	$-(0.625 \times 3) + 6.0$	= 4.12
		20	$-(0.641 \times 3) + 7.0$	= 5.07
		21		
		LEH A	$-(0.641 \times 3.5) + 6.0$	= 3.76
		LEH B	$-(0.641 \times 5.5) + 6.0$	= 2.48
		22	$-(0.588 \times 2.5) + 6.5$	= 5.03
		Ind C: 6		
LEH A	$-(0.625 \times 2) + 6.0$	= 4.75		
LEH B	$-(0.625 \times 2.5) + 6.0$	= 4.44		
LEH C	$-(0.625 \times 3.5) + 6.0$	= 3.82		
SDP6E-7	1	9		
		LEH A	$-(0.454 \times 2) + 4.5$	= 3.59
		LEH B	$-(0.454 \times 3.5) + 4.5$	= 2.91
SDP6E-8	4	23	$-(0.417 \times 4) + 4.0$	= 2.33
		24		
		LEH A	$-(0.460 \times 3.5) + 4.0$	= 2.39
		LEH B	$-(0.460 \times 6) + 4.0$	= 1.24
		25	$-(0.460 \times 4) + 4.0$	= 2.16
		26		
		LEH A	$-(0.417 \times 2) + 4.0$	= 3.16
		LEH B	$-(0.417 \times 5) + 4.0$	= 1.91
SDP6E-11	4	8	$-(0.454 \times 2.5) + 4.5$	= 3.36
		9		
		LEH A	$-(0.454 \times 1) + 4.5$	= 4.05
		LEH B	$-(0.454 \times 3) + 4.5$	= 3.14
		22	$-(0.588 \times 3) + 6.5$	= 4.74
		27		
		LEH A	$-(0.588 \times 1.5) + 6.5$	= 5.62
		LEH B	$-(0.588 \times 4) + 6.5$	= 4.15
SDP6E-12	1	22		
		LEH A	$-(0.588 \times 4) + 6.5$	= 4.15
		LEH B	$-(0.588 \times 5) + 6.5$	= 3.56

## APPENDIX B: FIGURES

## Figures



**Figure 1: Overview of Belize with Santa Rita Corozal indicated.**

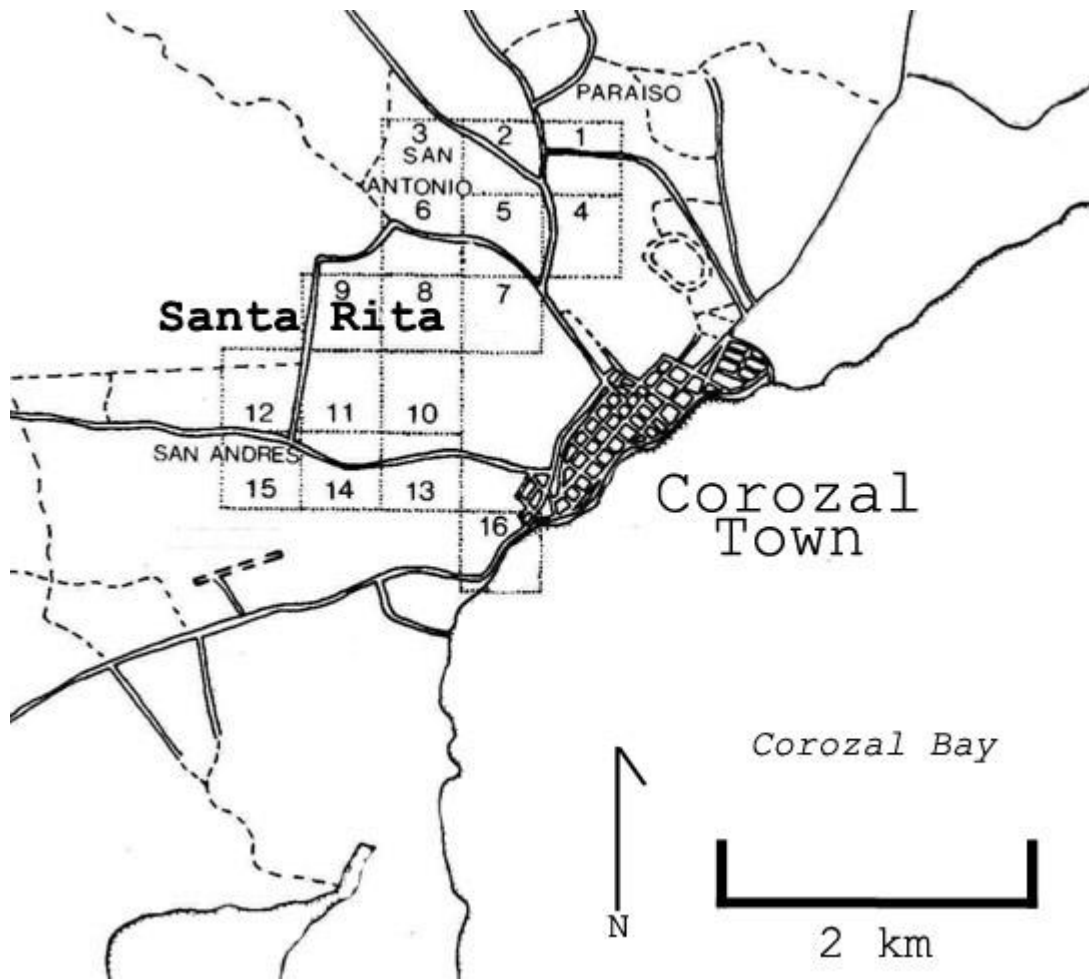

**Figure 2: Map of Santa Rita Corozal. Numbered grid squares represent areas mapped and/or excavated by DZ Chase during the field seasons at SRC (after Chase and Chase 1988:87).**

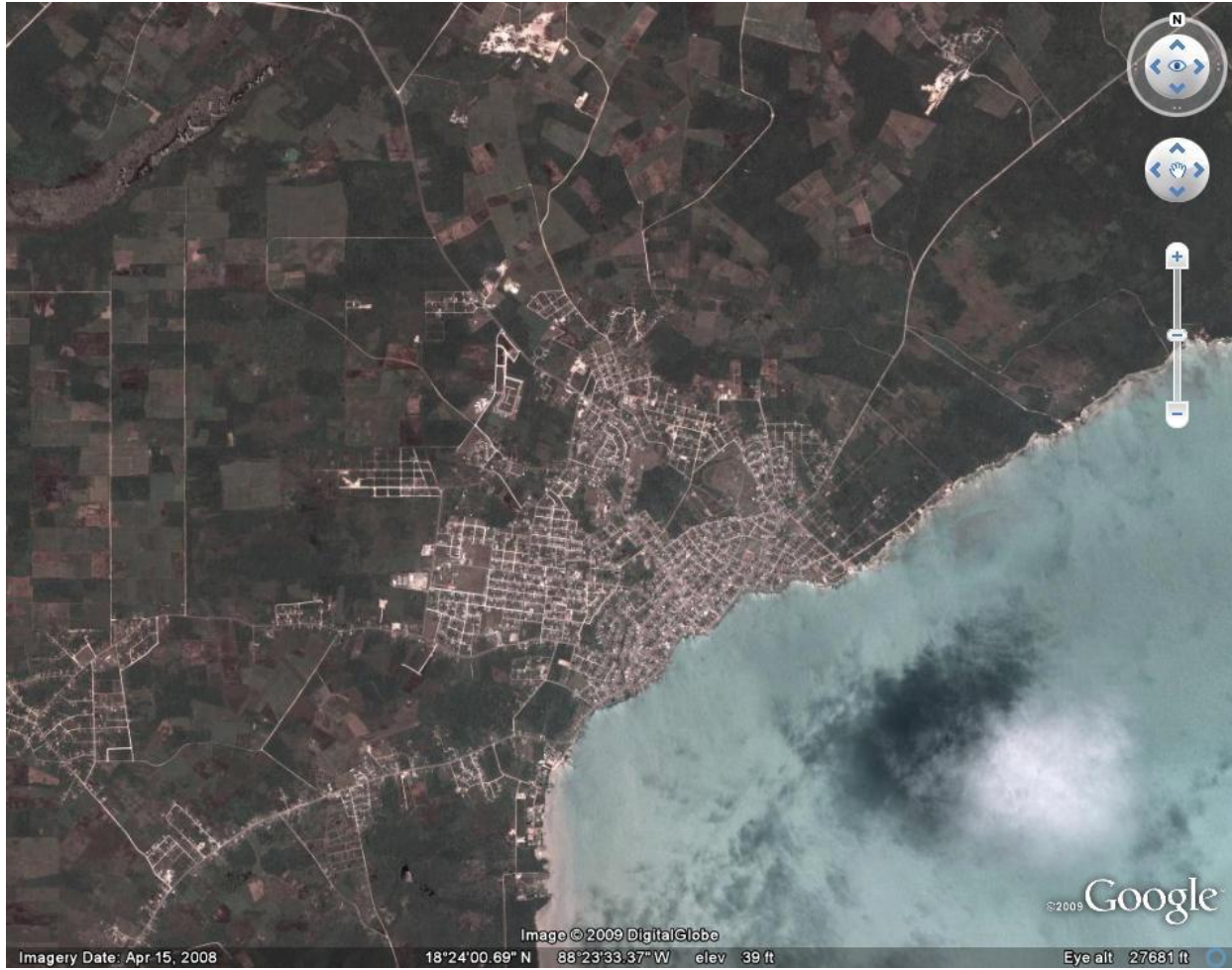

**Figure 3: Modern satellite view of Corozal town. Note the growing extent of modern construction that covers much of the Maya site of Santa Rita Corozal (Image Provided by Google Earth).**

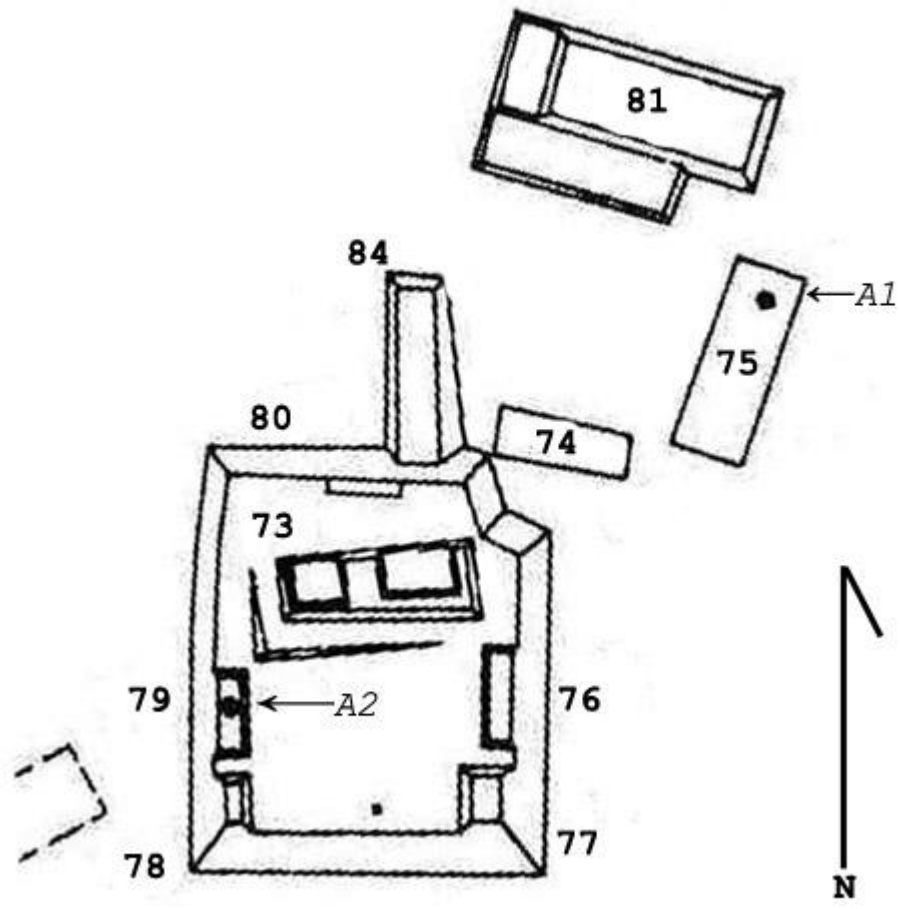

Figure 4: Enlarged view of Platform 2 and Structure 81 (after Chase and Chase 1988:89).



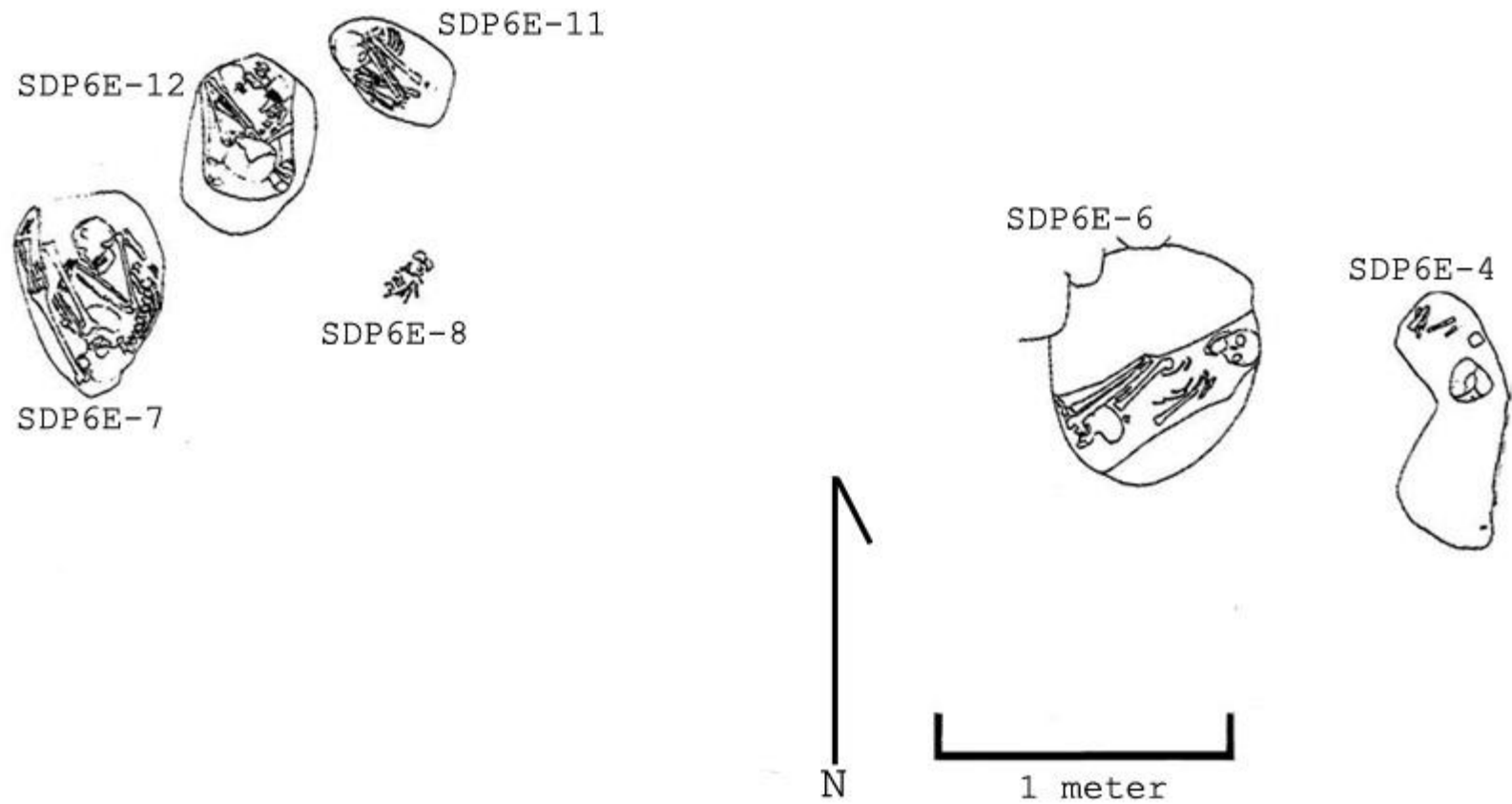
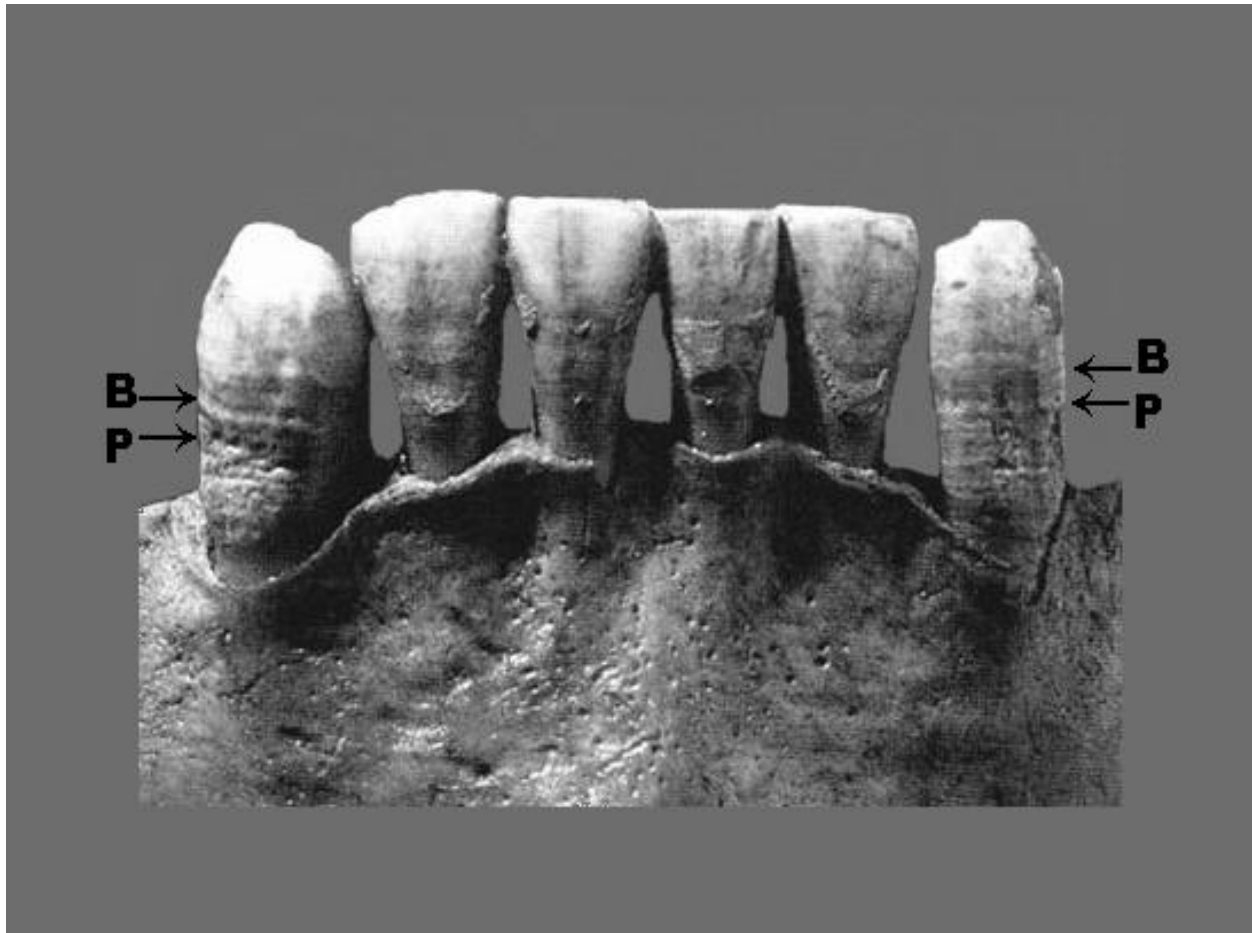
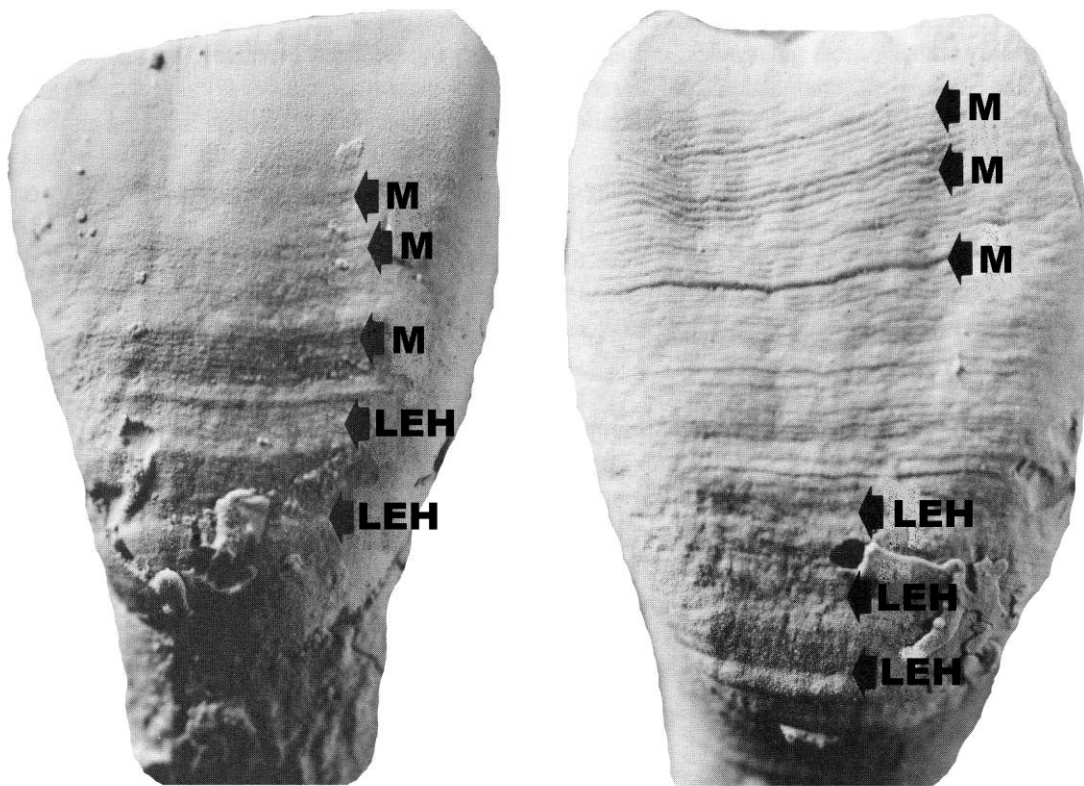

Figure 5: Plan view of Late Postclassic burials located directly south of Platform 2. Contains SDP6E-4, SDP6E-6, SDP6E-8, SDP6E-11, SDP6E-12, and SDP6E-5. SDP6E-5 is not shown because it is immediately above SDP6E-12 (after DZ Chase 1982:453).



**Figure 6: Case Example of LEH present on the dentition of a 12-year-old child. Note the distinct banding (B) and pitting (P) indicative of LEH on the canines (after White and Folkens 2000:403).**



**Figure 7: Case Example of Linear Enamel Hypoplasia present on two incisors. The indication LEH represents actual examples of LEH, while the label M represents features that are commonly mistaken for LEH (after Buikstra and Ubelaker 1994:56).**



**Figure 8: Extreme LEH banding apparent on dentition from P6E36 SDP6E-1. Individual A, PUNS#11. Age Estimate(Yr)/LEH Incident: A=5.06, B=3.5, C=2.56, D=1.65.**



**Figure 9: LEH Dentition from P6E36 SDP6E-1. Only minor banding is apparent. Individual C, PUNS#6. Age Estimate(Yr)/LEH Incident: A=4.75, B=4.44, C=3.82**

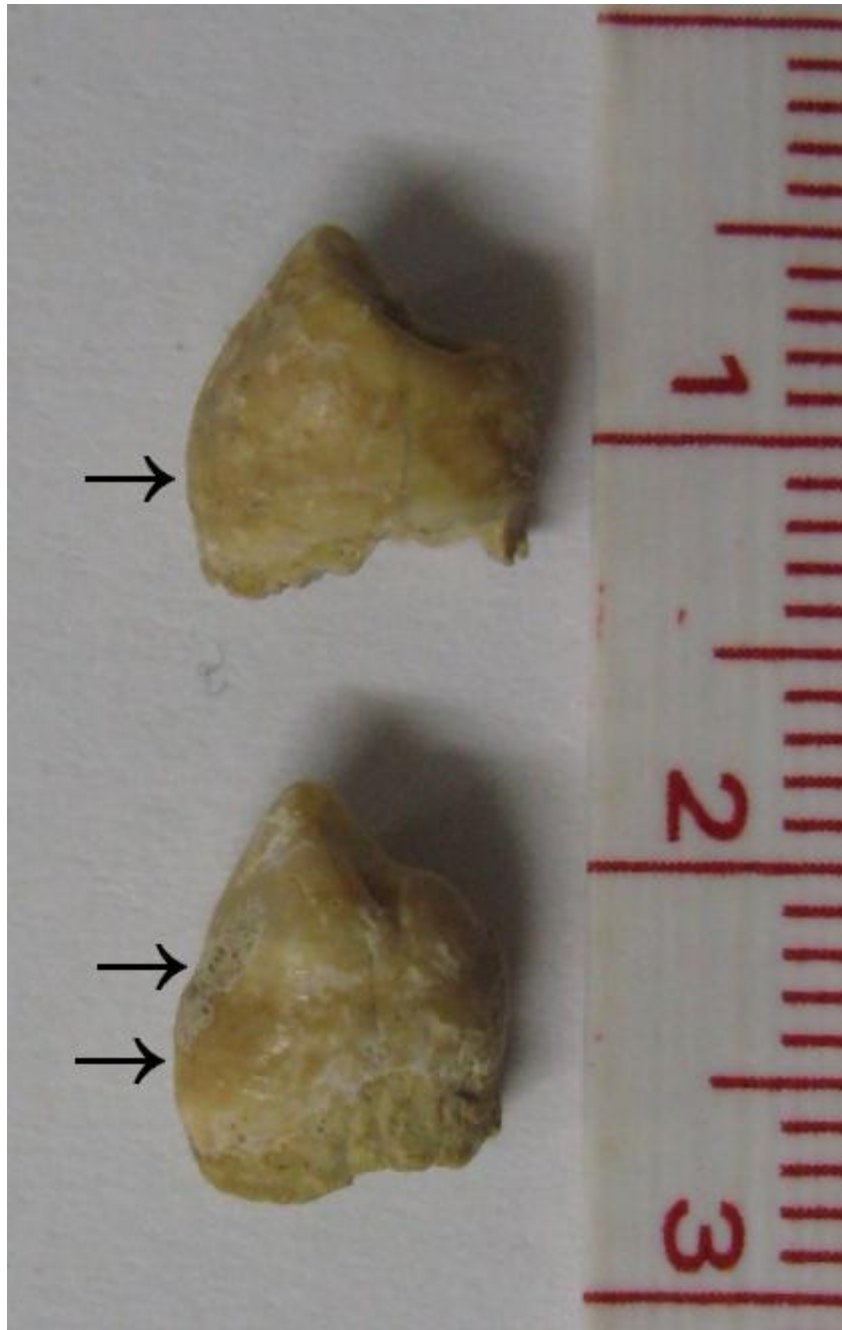

**Figure 10: LEH Dentition from P6E36 SDP6E-1. Only minor banding is apparent. Individual B, PUNS#20,21. Age Estimate(Yr)/LEH Incident PUNS#20: A=5.07 Age Estimate(Yr)/LEH Incident PUNS#21: A=3.76 B= 2.48**



**Figure 11: LEH Dentition from P6E36 SDP6E-1. LEH is quite apparent on the canine shown at the top of the image. Individual B, PUNS#6,22. Age Estimate(Yr)/LEH Incident PUNS#6: A=4.75, B=4.12 Age Estimate(Yr)/LEH Incident PUNS#22: A=5.03**



**Figure 12: LEH Dentition from P6E82 SDP6E-7. Only minor banding is evident. PUNS#9. Age Estimate(Yr)/LEH Incident: A=3.59, B=2.91**





Figure 13: LEH Dentition from P6E83 SDP6E-8. Moderate banding/pitting is evident. PUNS#24. Age Estimate(Yr)/LEH Incident: A=2.39 B=1.24



**Figure 14: LEH Dentition from P6E83 SDP6E-8. Minor banding is apparent beneath the calcium build-up.  
PUNS#26. Age Estimate(Yr)/LEH Incident: A=3.16, B=1.91**



**Figure 15: LEH Dentition from P6E83 SDP6E-8. Minor banding is apparent. It is possible this is evidence of a slight injury or trauma rather than an indicator of LEH. PUNS#23. Age Estimate(Yr)/LEH Incident: A=2.33**



**Figure 16: LEH Dentition from P6E83 SDP6E-8. Moderate banding is evident. PUNS#25. Age Estimate(Yr)/LEH Incident: A=2.16**



**Figure 17: LEH Dentition from P6E87 SDP6E-11. Moderate banding is evident on both incisors. PUNS#8,9. Age Estimate(Yr)/LEH Incident PUNS#8: A=3.36 Age Estimate(Yr)/LEH Incident PUNS#9: A=4.05, B=3.14**



**Figure 18: LEH Dentition from P6E87 SDP6E-11. Moderate banding is apparent. PUNS#27. Age Estimate(Yr)/LEH Incident: A=5.62, B=4.15**



**Figure 19: LEH Dentition from P6E87 SDP6E-11. Only moderate banding is evident. PUNS#22. Age Estimate(Yr)/LEH Incident: A=4.74**



**Figure 20: LEH Dentition from P6E88 SDP6E-12. Minor banding is evident. PUNS#22. Age Estimate(Yr)/LEH Incident: A=4.15, B=3.56**



## REFERENCES CITED

- Ash MM, and Nelson, SJ.  
2003 Wheeler's Dental Anatomy, Physiology, and Occlusion. Philadelphia: WB Saunders.
- Boldsen JL.  
2007 Early Childhood Stress and Adult Age Mortality: A Study of Dental Enamel Hypoplasia in the Medieval Danish Village of Tirup. American Journal of Physical Anthropology 132:59-66.
- Buikstra JE, and Ubelaker DH.  
1994 Standards for Data Collection from Human Skeletal Remains. Fayetteville: Arkansas Archaeological Survey.
- Chase DZ.  
2010 Personal Communication: September 27.
- 1997 Southern Lowland Maya Archaeology and Human Skeletal Remains: Interpretations from Caracol (Belize), Santa Rita Corozal (Belize), and Tayasal (Guatemala). In: Whittington SL and Reed DM, editors. Bones of the Maya: Studies of Ancient Skeletons. London: Smithsonian Institution Press. p 15-27.
- 1991 Lifeline to the Gods: Ritual Bloodletting at Santa Rita Corozal. In: Robertson MG and Fields VM, editors. Sixth Palenque Round Table, 1986. Norman: University of Oklahoma Press. p 89-96.
- 1985 Gained but not Forgotten: Late Postclassic Archaeology and Ritual at Santa Rita Corozal, Belize. In: Chase AF and Rice P, editors. The Lowland Maya Postclassic. Austin: University of Texas Press. p 104-125.
- 1982 Spatial and Temporal Variability in Postclassic Northern Belize. Ph.D. Dissertation, Anthropology Department, University of Pennsylvania.

- 1981 The Maya Postclassic at Santa Rita Corozal. *Archaeology* 34(1):25-33.
- Chase DZ, and Chase AF.  
2004 Exploring Ancient Economic Relationships at Caracol, Belize. *Research Reports in Belizean Archaeology* 1:115-127.
- 1988 A Postclassic Perspective: Excavations at the Maya Site of Santa Rita Corozal, Belize. San Francisco: Pre-Columbian Art Research Institute.
- 1986 Offerings to the Gods: Maya Archaeology at Santa Rita Corozal. Orlando: University of Central Florida.
- 1981 Archaeological Investigations at Nohmul and Santa Rita, Belize 1979-1980. *Mexicon* 3(3):42-44.
- 1980 Major Find from Maya Area Unearthed. *The New Belize* 10(8): 2-3.
- Chase DZ, Chase AF, and White CD.  
2001 El Paisaje Urbano Maya: La Integración de los Espacios Construidos y la Estructura Social en Caracol, Belice, In A. Ciudad Ruiz, Editors. *La Ciudad Antigua: Espacios, Conjuntos e Integración Sociocultural en la Civilización Maya*. Sociedad Española de Estudios Mayas, Madrid. p 95-122.
- Cucina A.  
2002 Diachronic Investigation of Linear Enamel Hypoplasia in Prehistoric Skeletal Samples from Trentino, Italy. *American Journal of Physical Anthropology* 119:283-287.
- Cucina A, and Iscan MY.  
1997 Assessment of Enamel Hypoplasia in a High Status Burial Site. *American Journal of Human Biology* 9:213-222.

- Cucina A, and Tiesler V.  
2003 Dental Caries and Antemortem Tooth Loss in the Northern Peten Area, Mexico: A Biocultural Perspective on Social Status Differences Among The Classic Maya. *American Journal of Physical Anthropology* 122:1-10.
- Danforth ME, Herndon KS, Propst KB.  
1993 A Preliminary Study of Patterns of Replication in Scoring Linear Enamel Hypoplasias. *International Journal of Osteoarchaeology* 3:297-302.
- Gerry JP, and Kruger HW.  
1997 Regional Diversity in Classic Maya Diets. In: Whittington SL, and Reed DM, editors. *Bones of the Maya: Studies of Ancient Skeletons*. Washington DC:Smithsonian Institution Press. p 196-207.
- Goodman AH, and Armelagos GJ.  
1988 Childhood Stress and Decreased Longevity in a Prehistoric Population. *American Anthropologist* 90:936-944.
- 1985 Factors Affecting the Distribution of Enamel Hypoplasias within the Human Permanent Dentition. *American Journal of Physical Anthropology* 68(4):479-493.
- Goodman AH, Martinez C, and Chavez A.  
1991 Nutritional Supplementation and the Development Of Linear Enamel Hypoplasias in Children from Tezonteopan, Mexico. *American Journal of Clinical Nutrition* 53:773-781
- Goodman AH, and Rose JC.  
1990 Assessment of Systemic Physiological Perturbations from Dental Enamel Hypoplasias and Associated Histological Structures. *Yearbook of Physical Anthropology* 33:59-110.

- Guatelli-Steinberg D, Larsen CS, Hutchinson DL.  
 2004        Prevalence and the Duration of Linear Enamel  
               Hypoplasia: A Comparative Study of Neandertals  
               and Inuit Foragers. *Journal of Human Evolution*  
               47:65-84.
- Hammond N, Pretty K, and Saul FP.  
 1975        A Classic Maya Family Tomb. *World Archaeology*  
               7(1):57-78.
- Hillson S, and Bond S.  
 1997        Relationship of Enamel Hypoplasia to the Pattern  
               Of Tooth Crown Growth: A Discussion. *American*  
               *Journal of Physical Anthropology* 104:89-103.
- Infante PF, and Gillespie GM  
 1974        An Epidemiologic Study of Linear Enamel  
               Hypoplasia of Deciduous Anterior Teeth in  
               Guatemalan Children. *Archives of Oral Biology*  
               19:1055-1061.
- Keita SY, and Boyce AJ.  
 2001        Diachronic Patterns of Dental Hypoplasias and  
               Vault Porosities During the edynastic in the  
               Naqada Region, Upper Egypt. *American Journal of*  
               *Human Biology* 13:733-743.
- Knick SG.  
 1982        Linear Enamel Hypoplasia and Tuberculosis in the  
               Pre-Columbian North America. *Ossa* 8:131-138.
- Larsen CS, Hutchinson DL, Stojanowski CM, Williamson MA, Griffin  
 MC, Simpson SW, Ruff CB, Schoeninger MJ, Norr L, Teaford  
 MF, Driscoll EM, Schmidt CW, and Tung TA.  
 2007        Health and Lifestyle in Georgia and Florida:  
               Agricultural Origins and Intensification in  
               Regional Perspective. In: Cohen MN, and  
               Crane-Kramer GMM, editors. *Ancient Health:*  
               *Skeletal Indicators of Agricultural and Economic*  
               *Intensification.* Gainesville: University Press of  
               Florida. p 20-34.

- Larsen CS, Kelly RL, Ruff CB, Schoeninger MJ, Hutchinson DL.  
 1996 Biobehavioral Adaptations in the Western Great Basin. In: Reitz EJ, Newsom LA, Scudder SJ, editors. Case Studies in Environmental Archaeology. New York: Plenum Press. p 149-169.
- Lovell NC, and Whyte I.  
 1999 Patterns of Dental Enamel Defects at Ancient Mendes, Egypt. American Journal of Physical Anthropology 110:69-80.
- Lukacs JR.  
 2001 Enamel Hypoplasia in the Deciduous Teeth of Great Apes: Variation in Prevalence and Timing of Defects. American Journal of Physical Anthropology 116:199-208.
- Malina R.  
 1998 Postnatal Growth and Maturation In: Ulijaszek SJ, Johnston FE and Preece MA, editors. The Cambridge Encyclopedia of Human Growth and Development. Cambridge: Cambridge University Press.
- McHenry HM, and Schulz PD.  
 1976 The Association between Harris Lines and Enamel Hypoplasia in Prehistoric California Indians. American Journal of Physical Anthropology 44(3):507-512.
- Mendez Colli C, Sierra Sosa TN, Tiesler V, and Cucina A.  
 2009 Linear Enamel Hypoplasia at Xcambo, Yucatan, During the Maya Classic period: An evaluation of Coastal marshland impact on ancient human Populations. Journal of Comparative Human Biology 60:343-358.
- Ortner DJ, and Putschar WGJ.  
 1981 Identification of Pathological Conditions in Human Skeletal Remains. Washington: Smithsonian Institution Press.

- Pechenkina EA, Vradenburg JA, Benfer RA, and Farnum JF.  
 2007 Skeletal Biology of the Central Peruvian Coast: Consequences of Changing Population Density and Progressive Dependence on Maize Agriculture. In: Cohen MN, and Crane-Kramer GMM, editors. Ancient Health: Skeletal Indicators of Agricultural and Economic Intensification. Gainesville: University Press of Florida. p 92-112.
- Ritzman TB, Baker BJ, and Schwartz GT.  
 2008 A Fine Line: A Comparison of Methods for Estimating Ages of Linear Enamel Hypoplasia Formation. American Journal of Physical Anthropology 135:348-361.
- Roys RL.  
 1957 The Political Geography of the Yucatan Maya. Washington D.C.: Carnegie Institution of Washington 613.
- Saul FP and Hammond N.  
 1974 A Classic Maya Tooth Cache from Lubaantun, Belize. Man 9(1):123-127.
- Saul JM and Saul FP.  
 1997 The Preclassic Skeletons from Cuello. In: Whittington SL and Reed DM, editors. Bones of the Maya: Studies of Ancient Skeletons. London: Smithsonian Institution Press. p 28-50.
- Sharer RJ, and Traxler LP.  
 2006 The Ancient Maya. Stanford: Stanford University Press.
- Skinner M.  
 1996 Developmental Stress in Immature Hominines from Late Pleistocene Eurasia: Evidence from Enamel Hypoplasia. Journal of Archaeological Science 23:833-852.

- Smith P, and Horwitz LK.  
2007       Ancestors and Inheritors: A Bioanthropological Perspective on the Transition to Agropastoralism in the Southern Levant. In: Cohen MN, and Crane-Kramer GMM, editors. Ancient Health: Skeletal Indicators of Agricultural and Economic Intensification. Gainesville: University Press of Florida. p 92-112.
- Starling AP, and Stock JT.  
2007       Dental Indicators of Health and Stress in Early Egyptian and Nubian Agriculturalists: A Difficult Transition and Gradual Recovery. American Journal of Physical Anthropology 134:520-528.
- Storey R.  
1999       Late Classic Nutrition and Skeletal Indicators at Copán, Honduras. In: White CD, editor. Reconstructing Ancient Maya Diet. Salt Lake City: University of Utah Press. p 169-179.
- 1997       Individual Frailty, Children of Privilege, and Stress in Late Classic Copan. In: Whittington SL and Reed DM, editors. Bones of the Maya: Studies of Ancient Skeletons. London: Smithsonian Institution Press. p 116-126.
- Weyers H.  
1977       A Particular Type of Dominant Hereditary Enamel Dysplasia. Deutsche Zahnärztliche Zeitschrift 32(3):243-247.
- Whittington SL.  
2000       Caries and Antemortem Tooth Loss at Copán: Implications for Commoner Diet. In: White CD, Editor. Reconstructing Ancient Maya Diet. Salt Lake City: University of Utah Press. p 151-167.

- Whittington SL, and Reed DM.  
 1997 Commoner Diet at Copan: Insights from Stable Isotopes and Porotic Hyperostosis. In: Whittington SL and Reed DM, editors. *Bones of the Maya: Studies of Ancient Skeletons*. London: Smithsonian Institution Press. p 157-170.
- 1989 Characteristics of Demography and Disease in Low Status Maya from Classic Period Copan, Honduras. Ph.D. Dissertation, Anthropology Department, Pennsylvania State University.
- White TD, and Folkens PA.  
 2000 *Human Osteology*. New York: Academic Press.
- Williams JS, White CD, and Longstaffe FJ.  
 2005 Trophic Level and Macronutrient Shift Effects Associated with the Weaning Process in the Postclassic Maya. *American Journal of Physical Anthropology* 128:781-790.
- Wright LE.  
 1997 Intertooth Patterns of Hypoplasia Expression: Implications for Childhood Health in the Classic Maya Collapse. *American Journal of Physical Anthropology* 102:233-247.
- 1990 Stresses of Conquest; A study of Wilson bands and enamel hypoplasias in the Maya of Lamanai, Belize. *American Journal of Human Biology* 2:25-35.
- Wright LE, and Schwarcz HP.  
 1998 Stable Carbon and Oxygen Isotopes in Human Tooth Enamel: Identifying Breastfeeding and Weaning in Prehistory. *American Journal of Physical Anthropology* 106:1-18.